

myford

ML7 LATHE

**NOTES ON
OPERATION
INSTALLATION
AND
MAINTENANCE
ALSO
PICTORIAL PARTS LIST**



**INCLUDING TRI-LEVA
SPEED SELECTOR LATHES**



ML7 LATHE

	<i>Page</i>
Outline diagram	2
Safety Precautions	2A
Specification	4
Standard and dismantled equipment	5
Assembly Instructions	7
Tri-Leva lathe assembly	10a
Installation	11
Lubrication	17
Controls and adjustments	21
Chuck fitting	31
Instructions for ordering spares	32
Parts lists	34

MYFORD ML7 3½" CENTRE LATHE

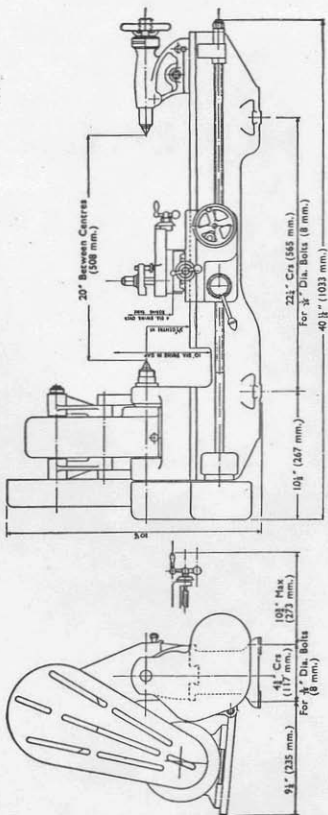

Fig. 1 Showing overall measurements for installation purposes

ATTENTION

General Safety Rules

All rotating machinery is a potential safety hazard and, therefore, care must be exercised at all times:

READ THE MANUAL CAREFULLY, especially familiarise yourself with the operation of all controls.

EARTHING. Make sure that the lathe and cabinet are electrically connected to an earthing point. If a 2-pronged connector is used an additional earthing wire should be run.

Switch 'OFF' before plugging in the connector to avoid accidental starting.

ALWAYS TURN THE SPINDLE BY HAND before switching on the motor. This will avoid damage to the bed, saddle or cross slide by swinging chuck jaws, workpiece, faceplate, bolts, etc.

CHECK THAT ALL HOLDING AND LOCKING DEVICES ARE TIGHTENED and that all keys and wrenches are clear of the moving parts of the machine.

WARNING — DANGER

This lathe has a screwed spindle nose.

Any resistance to rotation when running the spindle in reverse will unscrew a chuck, faceplate or any other attachment screwed to the spindle nose, which may result in a serious accident.

If you are unsure of the difference between forward and reverse directions, stand at the tailstock end of the lathe and view the headstock spindle along its axis. Forward rotation is achieved by an anti-clockwise movement of the spindle, whilst reverse rotation is clockwise.

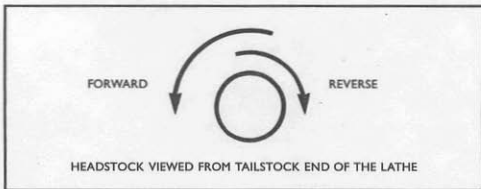

During installation of the machine it is important to remove any chuck, faceplate, or any other attachment from the spindle nose, even if they were fitted to the lathe at the time of delivery. Once all electrical connections/wiring have been completed, you **MUST** check that the direction of spindle rotation is correct before any attachment is screwed to the spindle nose. Inadvertently running the machine in reverse may lead to an attachment becoming unscrewed and a serious accident could result.

When the machine is wired with a reversing switch, care should be taken to ensure that the machine is only used in reverse at **LOW SPEED UNDER NO-LOAD CONDITIONS**.

Cleaning

All bright parts are protected with rust preventative. This must be removed with white spirit or similar and machined parts should be lightly oiled before any movement of parts is attempted.

After using the machine, any swarf should be cleaned away. Wipe the bed and other exposed surfaces with an oily rag.

It should be noted that when coolant is used this may cause staining. Therefore, if coolant is used, always clean the lathe thoroughly and re-oil.

MYFORD ML7 3½" CENTRE LATHE

DON'TS

- Do not allow untrained or unauthorised persons to start the machine.
- Do not raise the hinged guard for access to the secondary drive belt or remove the guard for access to the primary drive until all rotation of spindle and motor has stopped.
- Do not carry out maintenance or repairs with machine still connected to electrical supply.
- Do not interfere with electrical connections whilst still connected to electrical supply.
- Do not interfere with electrical equipment unless you are qualified to do so.
- Do not attempt to stop rotating parts by hand.

DO'S

- Do have adequate space in which to work and keep it tidy – cluttered machine trays and workbenches invite accidents.
- Do have sufficient lighting available.
- Do wear safety goggles or safety shield.
- Do avoid loose apparel – wear suitable protective clothing. Loose cuffs and neckties are particularly dangerous.



Unless you are familiar with the safe techniques necessary to operate this machine, do not use it until you have sought instruction/training from an experienced person.

MACHINE SERIAL No. FOR EARLY MACHINES

In the event of queries, or orders for spares, please state the number of the machine, as shown on the rear vertical face of the rear shear of the Lathe bed, at the tailstock end of the machine, Fig. 2.

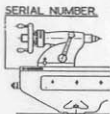

Fig. 2

MACHINE SERIAL No. FOR LATER MACHINES

In the event of queries, or orders for spares, please state the number of the machine, as shown on the front of the bed at the left hand end of the facing for the rack, Fig. 2.

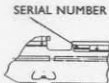

Fig. 2

Illustrations not binding in detail

MYFORD ML7 3½" CENTRE LATHE

THE MYFORD ML7 LATHE

The MYFORD ML7 Lathe illustrated is one of the most popular examples of the modern small screw cutting Lathe.

Outstanding features include the self-contained motor drive unit, and large tee-slotted boring table and the gap which allows work to be swung, which is larger than would normally clear the Lathe ways.

Note the complete guarding of the drive belts and changewheels, and the general heavy construction.

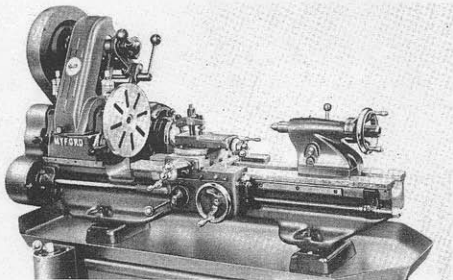

SPECIFICATION

Distance between centres	20 inch	32 inch
Swing over bed	7 inch	
Swing in Gap	10 inch	
Swing over boring table	4½ inch	
Hole through Spindle	19/32 inch	
Spindle Bored	No. 2 M.T.	
Spindle Speeds (six)	35-640 or 47-870 r.p.m.	
Feeds (Standard finest)0037 in. per rev.	
Boring Table Travel	5 inch	
Top Slide Travel	2½ inch	
Leadscrew	8 T.P.I. Acme	
Tailstock barrel bored	No. 2 M.T.	
Tailstock barrel travel	2½ inch	
Overall length	3 ft. 5 inch	4 ft. 5 inch
Overall width	2 ft. 1½ inch	
Nett weight (including motor) approx.	200 lb.	225 lb.
Nett weight on cabinet (incl. motor) approx.	320 lb.	375 lb.
Quick-change lathes	add =	16 lb.
Tri-Leva speed selector lathes	add =	11 lb.

A ½ h.p. 3 phase or ¼ h.p. single phase 1420/1450 r.p.m. full load speed motor is recommended. To ensure satisfaction, a suitable motor can be supplied by the factory. State whether A.C. or D.C., exact voltage and phase.

STANDARD & DISMANTLED EQUIPMENT

Unpacking

Great care is taken in the packing of ML7 Lathes to ensure that the user will receive the Lathe in perfect condition, and it is important that unpacking should be carried out with the same care in order to avoid possible damage.

Shortages

Check the standard equipment supplied with the machine; as listed, and illustrated below.

All loose packing material (such as wood wool) should be set aside and thoroughly searched in the case of apparent shortages. If the missing items do not come to light, report the shortages immediately to the supplier from whom the machine was purchased.

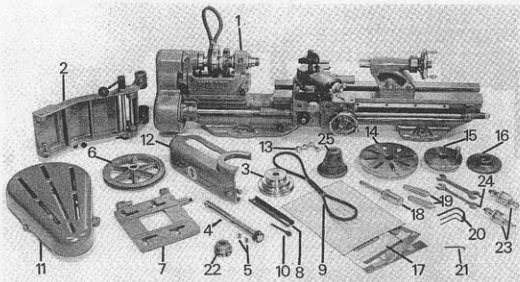

Illustration shows ML.7 Lathe with standard equipment dismantled for packing.

L'illustration montre le tour ML7 avec équipement standard démonté en vue de l'emballage.
Die Abbildung zeigt ML7—Drehbank mit Standard-Ausrüstung, demontiert zum Verpacken.

La fotografía muestra el torno ML7 con el equipo standard preparado para su embalaje.
A ilustração mostra o Torno ML7 com o equipamento normal desmontado para ser embalado.

DISMANTLED EQUIPMENT

1. Lathe partially dismantled for packing.
2. Unit comprising countershaft arm and swing head assembly.
3. Vee cone pulley for countershaft.
4. Countershaft with locating collar.
5. 2 "Woodruff" keys (No. 606).
6. Countershaft pulley.
7. Motor platform.
8. Tie bar for motor platform.
9. Vee belt for motor drive.
10. Support stud for motor drive belt guard.
11. Motor drive belt guard.
12. Headstock belt guard.
13. Ball handle for cross-slide.

STANDARD EQUIPMENT (LOOSE)

14. 6½" dia. Faceplate.
15. Driver plate with peg.
16. Not now supplied.
17. Descriptive matter, Installation Booklet etc.
18. Oil Gun.
19. Soft and Hard Centres.
20. 3 Hexagon keys.
21. Key for Back-gear lock.
22. Motor pulley.
23. 2 Sight feed lubricators.
24. 2 Spanners.
25. 8 Changewheels. (To complete standard set of 14—6 are mounted on the machine.)

For checking only. Do not use these numbers for ordering.

MYFORD ML7 3½" CENTRE LATHE

PIECES DEMONTEES—

1. Tour partiellement démonté en vue de l'emballage
2. Élément comprenant le bras de renvoi et basculeur-tendeur
3. Poulie à gradins du renvoi
4. Arbre de renvoi avec collier de blocage
5. 2 clavettes Woodruff (No. 90)
6. Poulie de renvoi (178 m/m ø)
7. Semelle pour moteur
8. Tirant de la semelle du moteur
9. Courroie trapézoïdale pour moteur
10. Goujon-soutien du capot de protection de la courroie moteur
11. Capot de protection de la courroie moteur
12. Capot de protection de la poulie.
13. Manivelle de commande du chariot transversal

Pour contrôle seulement — Ne pas utiliser ces chiffres pour commande.

EQUIPEMENT STANDARD (libre)

14. Plateau à rainures (170 mmø)
15. Plateau pousse-toc
16. Pas fourni
17. Littérature, notice de montage etc. . .
18. Pompe à huile
19. pointes douces et dures
20. 3 clés H.T.R.
21. clé pour déblocage du harnais
22. Poulie moteur
23. 2 lubrificateurs à valve
24. 2 clés plates
25. 8 pignons (complétant le jeu standard de 14 - six étant en place sur la machine),

Demontierte Ausrüstungsteile

1. Drehbank zum Teil demontiert, wie sie zum Versand kommt.
2. Antriebswippe mit Riemenspanner.
3. 3-stufige Keilriemenscheibe.
4. Vorgelegewelle mit Anschlag.
5. 2 Keilnutenkeile "Woodruff" (No. 90).
6. Keilriemenscheibe (178 mm ø) zu Vorgelegewelle.
7. Wippe zu Elektromotor.
8. Fixationsarm zu Motor-Wippe.
9. Keilriemen zu Motor-Vorgelege.
10. Tragbolzen zu Motor-Schutzhaube.
11. Schutzhaube zu Motor-Riemen.
12. Schutzhaube zu Spindelstockantrieb.
13. Winkelgriff zu Kreuzslitten.

Diese Zahlen 1 - 25 dienen nur zur Kontrolle beim Auspacken. Bitte beim Bestellen keinen Gebrauch dieser Nummern machen.

Standard-Ausrüstungsteile

14. Planscheibe (170 mm Durchmesser).
15. Mitnehmerscheibe mit Stift.
16. Nicht verschafft.
17. Katalog, Aufstellungs- und Bedienungsanweisung.
18. Oelspritze.
19. Je eine harte und eine weiche Spitze.
20. Drei Inbus-Schlüssel.
21. Schlüssel zur Schaltung des Reduktionsgetriebes.
22. Motor-Keilriemenscheibe.
23. 2 Sicht-Tropfboiler.
24. 2 Doppelgabelschlüssel.
25. 8 Wechselräder (zum ganzen Standardsatz von 14 Stück gehörend, 6 montiert auf Drehbank).

EQUIPO DESMONTADO

1. Torno desmontado parcialmente, listo para ser embalado.
2. Unidad que comprende el brazo del eje auxiliar y el conjunto principal oscilatorio.
3. Cono de poleas trapecoidales para el eje auxiliar.
4. Eje auxiliar con collar.
5. Dos clavetas "Woodruff" (No. 90).
6. Polvo del eje auxiliar (178 mm de diámetro).
7. Soporte del motor.
8. Tirante de sujeción del soporte del motor.
9. Correa trapecoidal.
10. Espérrago soporte para la protección de la correa del motor.
11. Protección de la correa del motor.
12. Protección de la correa del cabezale.
13. Manivela para el movimiento transversal del portaherramientas.

Para Probacion Solamente.
No Utilizar Estos Numeros Para Pedir Piezas.

EQUIPAMENTO DESMONTADO

1. Torno parcialmente desmontado para embalagem.
2. Unidade compreendendo o braço de contraveio e conjunto de cabeçote giratório.
3. Polie de cone em V para o contraveio.
4. Contraveio com anel para colocação.
5. 2 Chaves "Woodruff" (No. 90).
6. Roldanas de contraveio (178 m/m de diámetro).
7. Base do motor.
8. Barra de fixação da base do motor.
9. Correia trapecoidal para accionamento do motor.
10. Perno de suporte para resguardo de correa de accionamento do motor.
11. Resguardo da correa de accionamento do motor.
12. Resguardo da correa do cabeçote.
13. Manipulo para a espersa transversal.

Apenas Para Identificação Não Usar Estes Números
Para Encomendar.

EQUIPO STANDARD (INDEPENDIENTE)

14. Plato plano (170 mm de diámetro).
15. Plato para utilizar contrapunto.
16. No ahora suministrado.
17. Información de montaje y descripciones, instrucciones, etc.
18. Pistols de aceite.
19. Puntos: duro y blando.
20. 3 llaves exagonales.
21. Llave para el freno del mecanismo posterior.
22. Polea del motor.
23. 2 Lubrificadores visuales.
24. 2 llaves fijas.
25. 8 ruedas dentadas (para completar el juego "standard" de 14; seis están montadas en la máquina).

EQUIPAMENTO NORMAL (Peças soltas)

14. Prato liso de 170 m/m de diámetro.
15. Prato de transmissão com cavilha.
16. No fornecido.
17. Matéria descritiva, livrete de instalação, etc.
18. Pistola para óleo.
19. Pontos macios e rijos.
20. 3 Chaves hexagonais.
21. Chave de fixação do contraveio de mudança.
22. Polie do motor.
23. 2 lubrificadores de gota visível.
24. 2 Chaves de boca.
25. 8 rodas de muda (para completar jogo normal de 14—16 montadas no torno).

MYFORD ML7 3½" CENTRE LATHE

Cleaning

Myford machines are shipped with all parts protected by a rust preventative; all traces of this should be removed with either petrol or paraffin.

**DO NOT MOVE ANY PART OF THE MACHINE
UNTIL ALL OF THESE SURFACES HAVE BEEN
THOROUGHLY CLEANED AND OILED**

ASSEMBLY INSTRUCTIONS FOR MOTORISING EQUIPMENT

FOR LATHES FITTED WITH CLUTCH SEE ALSO PAGE 10a
FOR TRI-LEVA LATHES TURN TO PAGE 10a

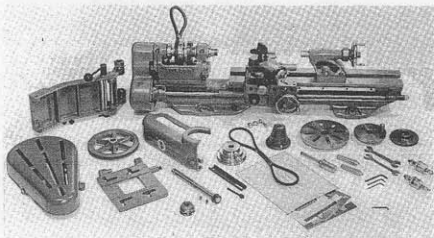

ML7 Lathes have the motorising equipment and cross slide ball handle dismantled for safe and economical packing purposes, these should be assembled on the machine by the method shown in this publication.

MYFORD ML7 3½" CENTRE LATHE

The number references used throughout these assembly instructions are those shown in Figures 3 and 10.

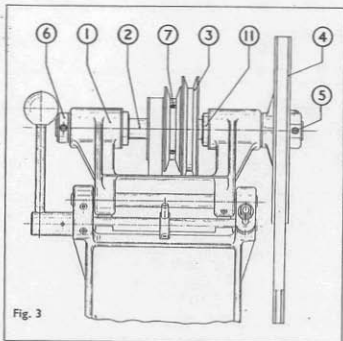

a Mount the countershaft arm/swing head assembly (1) on the back of the Lathe bed, using the three ¼" dia. x 1½" long B.S.F. screws and washers which are provided. See Fig. 4. Lightly tighten the screws only at this stage.

b Check that the rubber bushes (11) are in position, slide the countershaft (2) through the left-hand bearing of the swing head, (facing the rear of the machine), and slip the headstock vee belt over the countershaft, slide the countershaft into the vee cone pulley, (3) which should be held between the swing head bearings with the small step on the left. See Fig. 5.

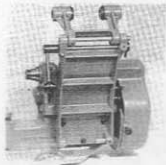

Fig. 4



Fig. 5

c Pass the countershaft into the vee cone pulley until the woodruff key seat approaches the pulley bore. Insert the woodruff key into the countershaft and engage with the keyway of the cone pulley. See Fig. 6.

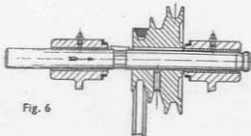

Fig. 6

MYFORD ML7 3½" CENTRE LATHE

d Slide the countershaft right through the remaining swing head bearing; place the fibre washer on the shaft and insert the second woodruff key at the extreme end of the countershaft (right hand end). Mount the vee pulley (4), and secure with the two socket grubscrews (5). Adjust the collar (6) to allow approximately .005" end float. See Fig. 7.

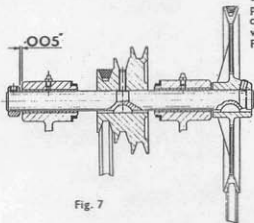

Fig. 7

e Position the countershaft cone pulley opposite the headstock cone pulley and lightly tighten the two securing screws (7).

(Note: A relief is provided in the countershaft for the securing screws). To ensure correct alignment of the countershaft and headstock spindle, place a straight edge across the face of

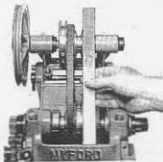

Fig. 8

the headstock cone pulley and adjust the position of the countershaft arm assembly, so that the headstock and the countershaft cone pulleys are parallel. See Fig. 8. Finally tighten the three countershaft arm fixing screws.

f Line up the countershaft cone pulley with the headstock cone pulley using the straight edge. Finally tighten the two securing screws (7).

g Pull the belt tensioning lever forward against the stop (i.e. with the lever and knob roughly vertical) so that the cam shaft (8) is in the full lift position. Adjust the tensioning screws (9) until the slack of the belt allows approx. ½" total movement when lightly oscillated by the thumb and forefinger. This will provide an initial tension setting, which can be increased if slip is experienced when the machine is operated. See Figs. 9 and 10.

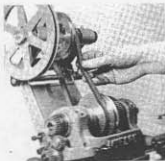

Fig. 9

h Remove the changewheel guard, assemble the motor base as shown in Fig. 11 (set as far to the right as possible), and secure by tightening the socket grubscrew in the right hand lug of the motor base.

Note: The socket grubscrew in the countershaft arm locates the assembly endwise, and should not be so tight as to prevent free swivelling of the motor base.

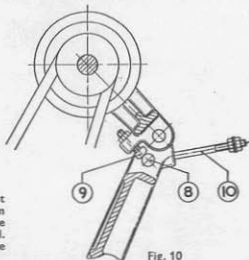

Fig. 10



Fig. 11

1 Attach the motor base link (with flanges innermost), and secure the motor base in a horizontal position. Place the motor and lightly tighten the bolts. If the motor is not required for reversing duty, it is recommended that the correct rotation be set before mounting. Rotation should be clockwise when viewed from the pulley end. Instructions for reversing rotation are usually contained in the motor terminal box. Assemble the motor pulley on to the motor shaft. Screw in the countershaft bolt guard stud (10), until tight, and attach the countershaft belt guard. See Fig. 12.

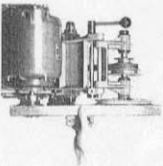

Fig. 13

to support the weight of the motor and base before securing the motor base link. The tension can be increased if slip is experienced in operation. Replace the countershaft belt guard.

1 Dismantle the two retaining plates from the headstock belt guard and slip the guard over the rubber bushes (11), on the swinghead. Replace the retaining plates.

Cross Slide Ball Handle—Assembly and Adjustment

Screw on the cross slide ball handle against the face of the feed dial, and

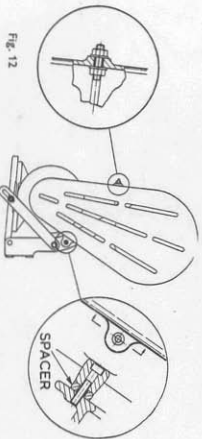

Fig. 12

1 Slide the motor as far to the right as is possible without fouling the countershaft belt guard, but still permitting sufficient adjustment of the motor pulley on the motor shaft for the lining up of the motor and countershaft pulleys. Remove the countershaft belt guard and use the straight edge to align the motor spindle and countershaft, and also to line up the motor and countershaft pulleys. See Fig. 13. Tighten the grub screw in the motor pulley.

k Release the motor base link, place the countershaft vee belt in position and adjust the belt tension. The initial tension setting is achieved by allowing the belt

continue to wind the cross slide until the front shoulder of the feedscrew makes firm contact with the face of the feednut in the saddle, to prevent rotation of the feedscrew.

Hold the feed dial with a spanner and slack-off the ball handle. Adjust the feed dial to eliminate excessive end play in the feedscrew bearing, and hold with the spanner whilst the ball handle is screwed forward to lock against the feed dial. An extremely tight adjustment is not necessary since end play does not affect the accuracy of the feed.

Wind the handle in both directions to ensure that the feedscrew rotates freely.

MYFORD ML7 3½" CENTRE LATHE

ASSEMBLY INSTRUCTIONS

Lathes, fitted with a clutch

Proceed as 'a' and 'b' on page 8 noting that in this instance the countershaft is complete with actuating shaft, collar, lever assembly and lever pivot bracket.

- c Pass the countershaft through the vee cone pulley, ensuring that the flats on the shaft are lineable with the grub screws in the cone pulley, and through the second bearing. Tighten the screws in the cone pulley just sufficiently to prevent the pulley from turning on the shaft but without securing the pulley.
- d At the driving end of the shaft, place in position the thrust washer P.22, see parts list at rear of booklet, and countershaft pulley assembly including the clutch assembly, lining up the grub screws in the backplate P.14 with the dimples in the shaft P.75. Locate the backplate on the shaft by tightening one grub screw. Release and remove the sleeve nut P.7 and withdraw lever P.8 keeping adjusting collar P.2 attached to it. Tighten securely both grub screws in backplate P.14. Replace washer P.2, lever P.8 and sleeve nut P.7 and tighten nut. Adjust collar at lever end of countershaft to give .005" end float to shaft, see Fig. 7 page 9. Position lever pivot bracket on swing head with outer end flush with boss on swing head and tighten grub screws. Continue as 'e' etc. to the end on pages 9 and 10.

Tri-Leva Lathes

- a Remove changewheel guard.
- b Place the fibre washer in position on the countershaft, insert the woodruff key into the keyway and mount the vee pulley on the shaft, and secure it by means of the two grub screws.
- c Check shaft for end float. See Fig. 7 page 9. Adjust the collar if necessary.
- d Fit the motor base, etc. as described at 'h', 'i', 'j', and 'k', pages 9 and 10, including fitment of countershaft belt guard and replace the changewheel guard.
- e After removing the hexagon nut and washer S.6 and S.38 (see parts list at rear of booklet) also hexagon head screw and spherical washers S.40 and S.41, place the main frame unit over the swing head and lower it on to the front of the lower trap. Replace the hexagon nut also the spherical washers and hexagon head screw, ensuring that there is a spherical washer on each side of the support bracket S.39.

Partially lock the main frame in a position where the radial profile at the base of the main frame is approximately central with the headstock bearing caps. Position the main frame to bring the jockey pulleys in line with the belt and lock.

INSTALLATION

Foundation

It is essential that the Lathe be placed on a solid foundation. The floor material is an important consideration, concrete being the most satisfactory. If the floor is of flimsy construction, a possible solution is to cut a hole through the floor and build up a concrete foundation from the ground up to the floor level.

If the machine is to be located on an upper floor of timber construction, it should be placed directly over a beam or girder, near a wall, or at some other spot where displacement of the floor will be at a minimum.

Floor Stands

The MYFORD steel cabinet stands make ideal supports for the lathe. See Fig. 15. Wooden benches are not recommended, as they are affected by moisture and atmospheric changes. Despite the rigidity of the Lathe, a warping bench can upset the level of a Lathe in the space of a few days, and greatly impair its accuracy.



Fig. 15. Tray-top Cabinet with deep tray, raising blocks and terminal block only.

MYFORD ML7 3½" CENTRE LATHE

If the user is compelled to use a wooden bench, good dry timber must be used. The structure should be solidly built, well braced and should be securely bolted to the floor. A piece of steel sheet should be placed on the bench top to prevent the Lathe feet from sinking into the wood surface under the bolting down pressure.

The 20/024 drip tray used in conjunction with 20/025 pair of raising blocks with levelling screws will serve very well for this purpose (see Fig. 17).



Fig. 17 Drip Tray

Lathe Height

A bench height of 33-34 inches is suitable for the man of average height. Alternatively, a comfortable working height can be gauged by arranging the lathe so that the upper surface of the topslide is at elbow height.

Before bolting down, the floor stand should be packed under the feet until the top surface is roughly level.

Levelling the Lathe

If the lathe is not properly levelled, the lathe bed may be twisted, resulting in misalignment of the headstock or tailstock with the ways, causing the lathe to turn and bore taper. **ACCURATE WORK CANNOT BE EXPECTED IF THE LATHE IS NOT LEVEL.**

The precision built into a Lathe can be completely nullified by faulty, uneven mounting on bench or floor stand.

Levelling should be carried out by placing shims of thin metal or asbestos sheet jointing under the Lathe feet, the amount of packing being determined with an Engineer's precision level. Where the lathe is mounted on raising blocks having jackscrews, packing shims are not required. The level, which should be sufficiently sensitive to read .003" per foot or better, should be placed across the bed at both the headstock end and the tailstock end. See Fig. 18. After bolting down re-check for level, and make any further necessary adjustments.

Do not try to level the lathe by packing under the cabinet or bench.

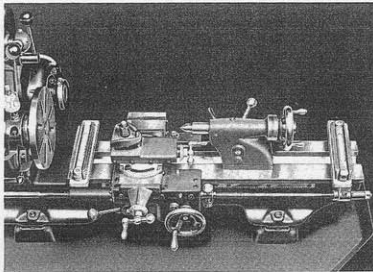

Fig. 18

Illustration of bed with precision levels at two points.

MYFORD ML7 3½' CENTRE LATHE

Levelling with a Dial Test Indicator

If a precision level is not available, use a dial test indicator in the following manner, to ensure that no distortion of the lathe bed takes place when bolting down:—

Place the Lathe on the bench or floor stand with the holding down bolts loosely in position.

Grip a piece of 1" diameter material in the chuck with approximately 8" protruding, and clamp the dial indicator in the tool post with the plunger located at the extreme end of the test bar as shown in Fig. 19.

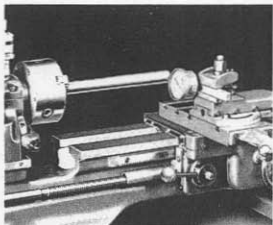

Fig. 19

Showing test piece in chuck and dial indicator in tool clamp.

Rotate the headstock spindle by hand, and adjust the dial indicator, so that the zero mark lies midway between the extremes of the pointer movement.

So long as the lathe bed is not strained the dial indicator will continue to register zero when holding down bolts are tightened but any distortion due to bolting down on to an uneven surface will be shown immediately by the dial indicator.

The lathe feet should be shimmed, so that, when the holding down bolts are finally tight, the dial indicator still reads zero.

Checking the Levelling

A final check of the levelling can be carried out by turning a test piece as shown in Fig. 20. The test piece should be approximately 1" dia. by 4" to 6" long and should be relieved in the middle so as to leave about ¼" for test turning at each end.

Take a very light finishing cut, (.002") across both collars without the use of the tailstock and without alteration of the tool setting. Measure the dia. of each collar with a micrometer. The collars should be the same dia., if not the same, a further adjustment of the packing is required.

If the dia. of the test piece is larger at the free end, packing should be increased under the FRONT of the foot at the tailstock end, or under the BACK of the foot if smaller.

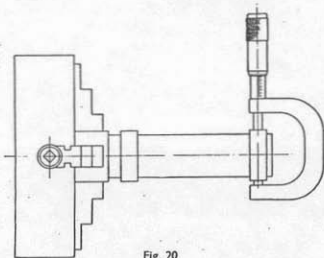

Fig. 20

Showing test piece with two collars

Readjustment

It may be necessary to readjust the packing shims from time to time, especially if the lathe is mounted on a wooden floor or bench.

Electric Motors and Switch Wiring (not applicable for two speed Tri-leve lathes)

The lathe is designed for use with a 1425 r.p.m., 50 Hz or 1750 r.p.m., 60 Hz motor. For three phase supply this should be $\frac{1}{2}$ h.p. For single phase on the ML7, $\frac{1}{2}$ h.p. is required to provide the necessary starting and pull out torque. Suitable motors, with a choice of switch control gear, are available.

Primary belt tension is obtained by moving the motor up or down on the countershaft arm, which is drilled for the mounting of motors which have slotted feet.

It is also provided with slots so that motors in IEC frame 71, having holes in the feet, can be readily accommodated. Any other motor having holes in the feet must be mounted on steel strips with studs, suitably disposed so as to pass through slots in the countershaft arm.

There are two basic types of switch control gear. The first, which is best suited to the home user, is a rotary reversing switch. This incorporates no-volt release which, in the event of a power break, will automatically return to the 'off' position. They are suitable for bench mounted lathes and lathes fitted to tray top cabinet stands. The switch comes complete with switch to motor wiring harness, a gland ready fitted to take customers' supply cable and a packing block which allows for either bench or cabinet mounting.

The second type of switch control gear - the complete safety switch package - is essential for both Industrial and Educational installations. This comprises: a lockable isolator switch, reversing push button starter with no-volt and overload release protection, mushroom head stop button operating on 110 volt control circuit, and a 12 volt tapping for a safe worklight. The package comes complete with switch to motor wiring harness, a gland ready fitted to take customers' supply cable and a packing block which allows for either bench or cabinet mounting.

Single phase motors, purchased independently, but intended for reversing with our switch control gear, must have four terminals for the separate connections to the starting and running windings. Any bridge pieces connecting starting to running windings must be removed before connecting motor to reversing switch.

MYFORD ML7 3½" CENTRE LATHE

Wiring diagrams for motors used in conjunction with Rotary Reversing Switch

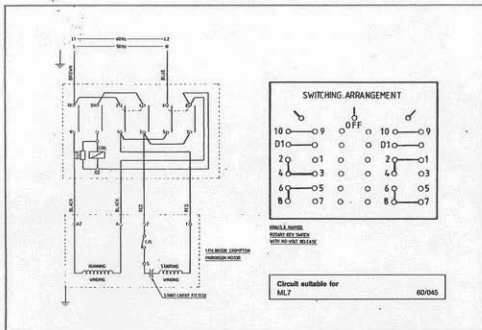

Fig. 3 Single Phase

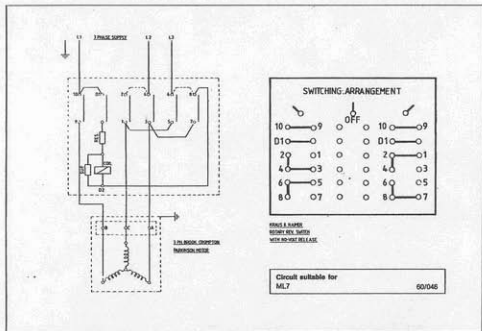

Fig. 3a Three Phase

MYFORD ML7 3½" CENTRE LATHE

Complete electrical switch package

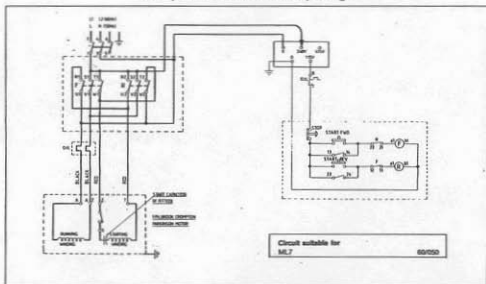

Fig. 4 Single Phase

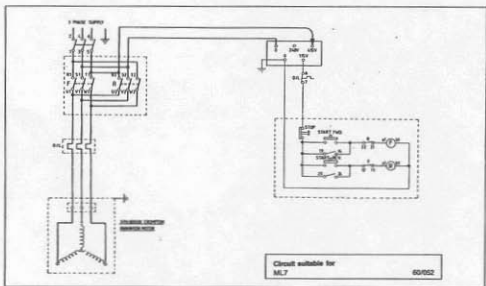

Fig. 4a Three Phase

MOTOR	STARTING WINDING	RUNNING WINDING	RUNNING WINDING	STARTING WINDING
CROMPTON	Z	A	A2	T
AEI	A1	T2	T3	A2
ENGLISH ELECTRIC	1	2	3	4
BROOK	Z1	A1	A2	Z2

Terminal markings of alternative makes of motors

Fig. 5

Earthing It is important to make sure that the stand and the Lathe are electrically connected to a satisfactory earthing point. Should any difficulty be found in wiring and running the motor the advice of an electrician, who is competent in motor wiring, should be sought.

LUBRICATION

After installing the Lathe, refer to the lubrication charts on Pages 19 and 20 and treat all points with the recommended lubricants. An oil gun is supplied for use with the pressure nipples fitted to each machine. Careful attention should be paid to the lubrication of the headstock bearings during the first few hours of running.

Headstock Bearings

The ML7 headstock bearings are lubricated from sight feed lubricators, Fig. 28. Feed is controlled by a needle valve which is adjusted by the thumb screw nut at the top of the lubricator, the oil drip being visible through a sight glass below the valve.

Normally the drip should be set as slow as possible but if prolonged high speed is undertaken the rate may be increased.

The lubricator is filled by inserting an oil can spout into one of the filler caps on the oil reservoir.

SIGHT FEED LUBRICATOR

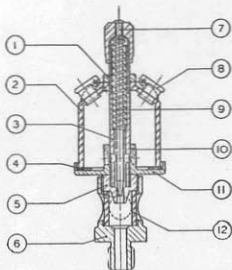

Fig. 28

1. LOCKING NUT
2. RESERVOIR
3. STAND PIPE
4. CORK SEALING WASHER
5. CHAMBER BUSH
6. SIGHT CHAMBER
7. NEEDLE VALVE ASSEMBLY
8. FILLER CAP
9. SPRING
10. OIL FILTER
11. RESERVOIR BASE
12. SIGHT GLASS

MYFORD ML7 3½" CENTRE LATHE

IMPORTANT: WHENEVER THE HEADSTOCK REDUCTION GEAR IS USED, ENSURE THAT THE HEADSTOCK PULLEY BEARING IS WELL LUBRICATED VIA THE OIL NIPPLE AT THE LARGE END OF THE PULLEY. Fig. 29.

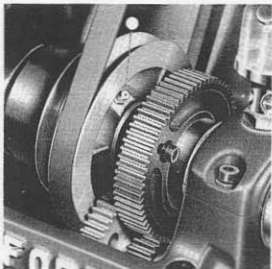

Fig. 29. Showing the oil nipple for headstock pulley bearing lubrication

General

Daily cleaning and correct lubrication of the machine will greatly increase its working life. Excess oil should be wiped from oiling points, as oil and dirt form an abrasive compound which can easily damage precision bearing surfaces.

Wipe the bed and other sliding surfaces with a clean oily rag at frequent intervals. Use a brush to clean spindle nose threads, gear teeth, leadscrew threads etc.

At regular intervals, the leadscrew should be thoroughly cleaned with a stiff brush and paraffin, and oiled freely along its entire length.

Keep the lathe completely covered between working periods. The MYFORD waterproof Lathe cover shown in Fig. 30 will provide excellent protection from moisture and abrasive dust when the Lathe is not in use.

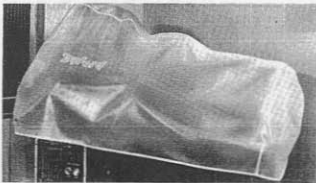
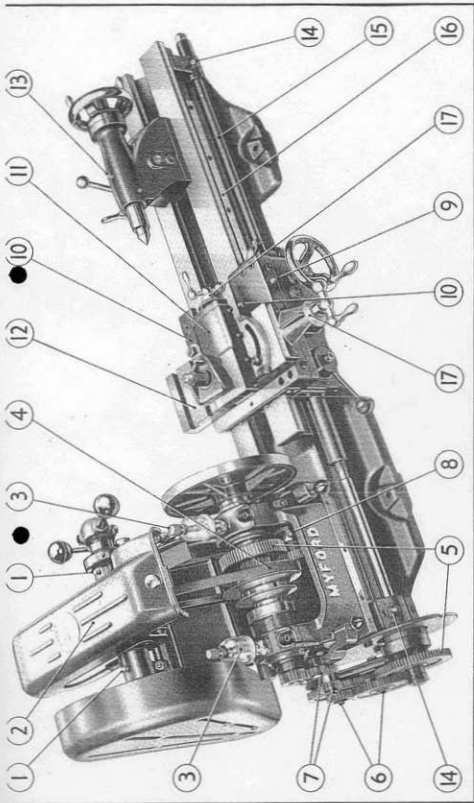
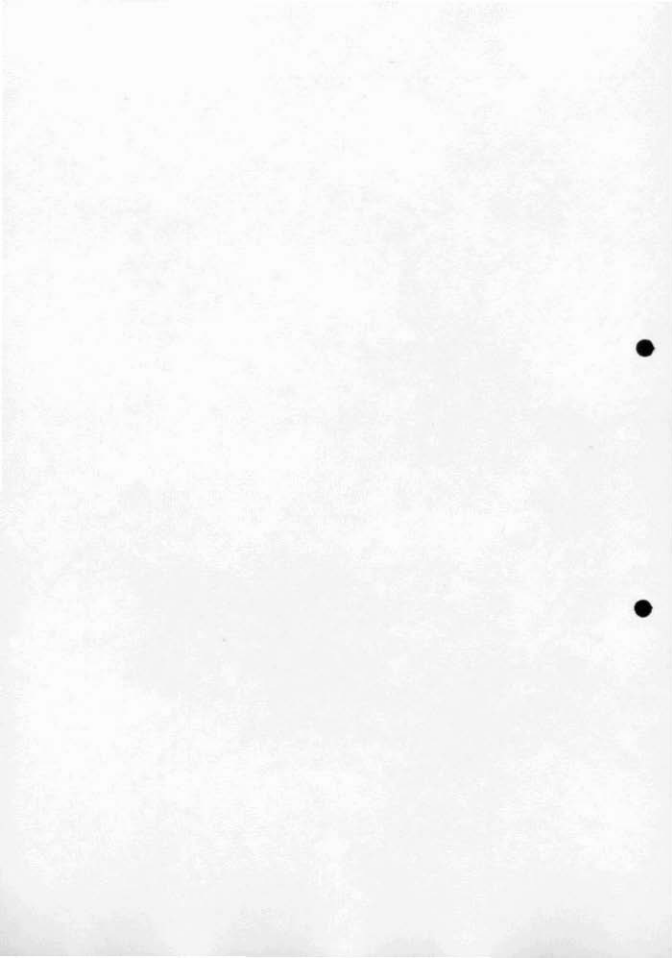

Fig. 30. Lathe cover.



LUBRICATION CHART. Use 80024 Esso Nuto H32 except where otherwise stated (Under I.S.O. VG32)

- AT REGULAR INTERVALS**
1. **Countershaft.** Use the oil gun on both nipples.
 2. **Headstock Bearings.** Check the oil level of Sight Glass. Lubricate when necessary.
 3. **Headstock Pulley.** Lubricate when necessary.
 4. **Headstock Pulley.** Lubricate when necessary.
 5. **Backgears and Change gear teeth.** A small amount of 80025 Esso Felis K&B will effectively lubricate.
 6. **Change wheel teeth.** Oil frequently.
 7. **Turntable Gears.** These last running components should be frequently lubricated whenever the gears are being used.
 8. **Backgear Spindle.** Use the oil gun frequently, whenever the reduction gear is used.
 9. **Apron Reservoirs.** Use the oil gun. This supply is distributed to the handwheel and rack pinion shafts and also feeds the reduction gear.
 10. **Saddle.** Use the oil gun on both nipples; one over the front rollers, one at the rear.
 11. **Topslide Ways.** Clean and apply 80025 Esso Felis K&B.
 12. **Cross-slide Ways.** Clean and apply 80025 Esso Felis K&B.
 13. **Tailstock Barrel.** Use the oil gun on nipple shown.
 14. **Swing Head Pin and Eccentric.** Apply 80025 Esso Felis K&B.
 15. **Lead screw Brackets.** Use the oil gun on both nipples.
 16. **Rack.** Apply 80025 Esso Felis K&B.
 17. **Cross-slide and Topslide Feed screws.** Oil occasionally from underside using 80025 Esso Felis K&B.
- NOTE.** We highly recommend Esso Nuto H32 Oil for general lubrication.
- For starred items Nos. 5, 7, 15, 16, 17, Acrol MTS 1000 or Castrol H53 Grease should be used in those territories where it is available.
- N.B. The frequency of lubrication given above is intended as a guide only. Use of the oil gun on the bearings of feedset screws, the countershaft, headstock bearing, change wheel studs, etc. will require more frequent lubrication.



MYFORD ML7 3½" CENTRE LATHE
CONTROLS & ADJUSTMENTS

DO NOT OPERATE THE LATHE until all of the following instructions have been carefully read and the controls and adjustments are fully understood.

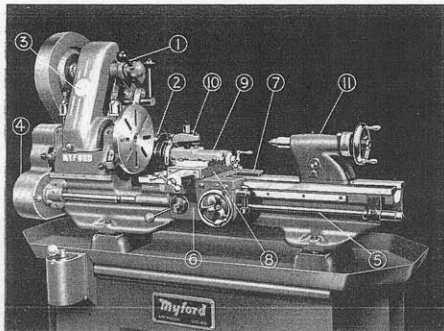

Fig. 31 Showing the main parts of the lathe.

(Fitted 1466 Countershaft Clutch)

- | | |
|--------------------------------|-----------------|
| (1) COUNTERSHAFT | (7) SADDLE |
| (2) ELECTRIC MOTOR | (8) CROSS SLIDE |
| (3) HEADSTOCK | (9) TOPSLIDE |
| (4) LEADSCREW DRIVE GEAR TRAIN | (10) TOOLPOST |
| (5) LEADSCREW | (11) TAILSTOCK |
| (6) APRON | |

MYFORD ML7 3½" CENTRE LATHE

Headstock Spindle Drive

A compact motorising unit which makes the ML7 completely self contained, is attached to the rear of the lathe bed. The motor is mounted on a swinging platform and the drive is conducted by vee belt from the motor to a countershaft. The vee cone pulleys on the countershaft and headstock spindle give a range of three speeds which is extended to six by the provision of a 6 - 1 reduction gear on the headstock spindle. Fig. 32.

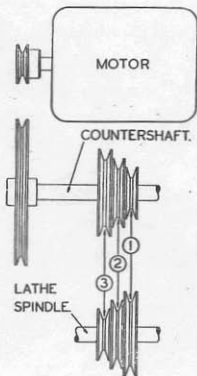

Fig. 32

HEADSTOCK SPINDLE SPEEDS.				
(1420/1450 R.P.M. FULL LOAD SPEED MOTOR)				
SPINDLE SPEEDS WITH 1750 R.P.M. (60 CYCLE A.C.) MOTOR IN BRACKETS				
Headstock Belt Position	1½" Dia. Motor Pulley (Standard)		2½" Dia. Motor Pulley	
	Ungeared	Geared	Ungeared	Geared
1	200 (246)	35 (43)	273 (338)	47 (58)
2	357 (438)	62 (76)	487 (600)	84 (103)
3	640 (785)	110 (135)	870 (1070)	152 (187)

MYFORD ML7 3½" CENTRE LATHE

Speed Changing

Access to the headstock belt for speed changing is attained by sliding up the front guard, as shown in Fig. 33 and the headstock belt tension is released by the operation of the belt tensioning lever.

DO NOT ATTEMPT TO CHANGE THE HEADSTOCK BELT POSITION WHILST THE LATHE IS RUNNING, OR WITHOUT OPERATING THE BELT TENSIONING LEVER

The coupling of the pulley to the spindle for direct or ungeared driving is achieved by a sliding key which engages with the headstock pulley sleeve gear. The sliding key is locked in position by means of a cap head screw, which is released to withdraw the key whenever the geared speeds are required.

To operate the reduction gear, withdraw the sliding key and shift the back gear operating lever to the upper position.

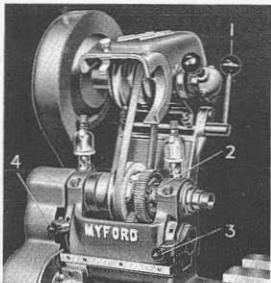

Fig. 33. Location of the Headstock Controls.

- (1) BELT TENSION RELEASE LEVER (3) BACK GEAR LEVER
(2) SCREW FOR BACK GEAR KEY (4) TUMBLER REVERSE LEVER

DO NOT ATTEMPT TO ENGAGE THE REDUCTION GEARS WHILST THE SPINDLE IS REVOLVING

MYFORD ML7 3½' CENTRE LATHE

Headstock Bearings

The headstock is fitted with Glacier T.1 Alloy anti-friction bearings. Top and bottom bearing halves are fitted accurately in the bearing housing and form a solid support against spindle journal loads. Every care is taken to ensure correct bearing adjustment before the machine leaves the Works, and bearings should not be interfered with unless necessary. For the purpose of bearing adjustment, a pad comprised of brass shims is fitted between the two housing faces. This shim pad has a solid appearance but is made of .002" laminations, and by inserting a penknife blade it is an easy matter to peel off the desired thickness to allow the bearings closer contact with the spindle. After removing a .002" shim it will be necessary to scrape or file some proportional amount from the bearing half contact faces, giving a good seating to bearing halves and housing cap; in effect a solid condition with running clearance only between spindle and bearing. Whenever bearings need adjustment use marking blue for contact check, carefully scraping any high spots with a half round bearing scraper.

Spindle end thrust adjustment is made by the screwed collar at the end of the Spindle, and care should be taken to ensure the elimination of end float without undue friction by over tightening.

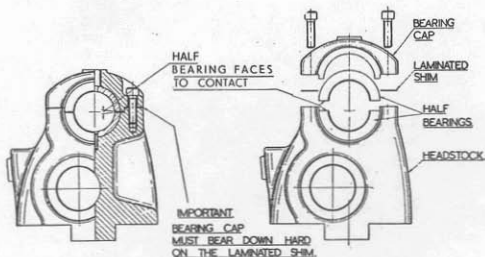

Fig. 34—Showing Method of Adjusting ML7 Lathe Headstock Bearings.

Replacement of Headstock Vee Belt

The vee rope can readily be replaced when necessary by removing the bearing caps and lifting out the spindle assembly as a complete unit; care should be taken to ensure that the shims are replaced in the same positions and that the caps are locked up tight after replacement.

Replacement of Headstock Vee-Belt—Tri-Leva Lathes

- Remove the main frame unit; see assembly instructions, 'e', page 10a.
- Remove cheesehead screw and washer S.60 and S.61 which fasten link S.59 (see parts list at end of booklet) to upper belt trap. Unscrew caphead screws S.10 which hold clamps S.9 and S.11 to upper belt trap S.8. The clamps and belt trap may now be removed.
- Dismantle headstock spindle and countershaft as for basic machine.

N.B. When replacing upper belt trap do not over tighten screws S.10 which secure the clamps. The upper trap should be free to move by normal hand pressure. The slotted link S.59 is left free until, with the screws tightened as above, the trap has been positioned to give approximately ¼ inch clearance between the inner face of the trap and the outer face of the belt. When the trap has been positioned replace screw and washer S.9 and S.11 and tighten.

TUMBLER REVERSE

The Tumbler Reverse or Leadscrew Reverse gear, provides a quick means of changing the rotation of the leadscrew drive to reverse the direction of travel of the lathe carriage. The central lever position is neutral and disengages the leadscrew drive.

**DO NOT MOVE THE TUMBLER REVERSE LEVER
WHILST THE SPINDLE IS REVOLVING**

POWER CARRIAGE FEEDS

Standard change gear lathes are equipped with a set of 14 change wheels for cutting various screw threads and obtaining various power longitudinal feeds.

To set up the lathe for threading or feeding, refer to the change wheel chart inside the change wheel guard Figs. 37 and 38.

The thread pitch, or feed, to be set up will be located in the first two columns under the headings T.P.I. and Feed per Rev., respectively. In the third column under the heading DRIVER is listed a number of teeth in the change wheel which should be placed on the tumbler reverse stud.

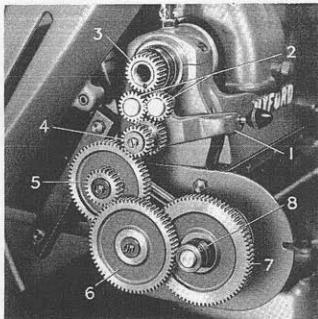

Fig. 35. Showing Leadscrew Drive.

- | | |
|---------------------------|--------------------|
| (1) TUMBLER REVERSE LEVER | (5) 1st STUD GEARS |
| (2) TUMBLER REVERSE GEARS | (6) 2nd STUD GEARS |
| (3) 25T SPINDLE GEAR | (7) LEADSCREW GEAR |
| (4) TUMBLER CLUSTER GEAR | (8) SPACER |

MYFORD ML7 3½" CENTRE LATHE

In the fourth and fifth columns under 1st stud and 2nd stud are shown the gears or pairs of gears which should be placed on the 1st and 2nd studs respectively.

The 6th column lists the gear to be placed on the leadscrew under the heading LEADSCREW.

The column headed SET-UP refers to the number of the diagram, Fig. 36, which will indicate the arrangement of gears and spacers for the pitch in question, see also Fig. 35 which shows set-up as in Diagram 3, Fig. 36.

When setting up the gear train sufficient backlash between each pair of meshing gears should be allowed. When the lathe is in operation the play in the gears is automatically taken up according to the direction of travel; the amount of gear clearance does not influence the accuracy of thread cutting. Gear noise can be reduced by the application of grease, preferably graphited.

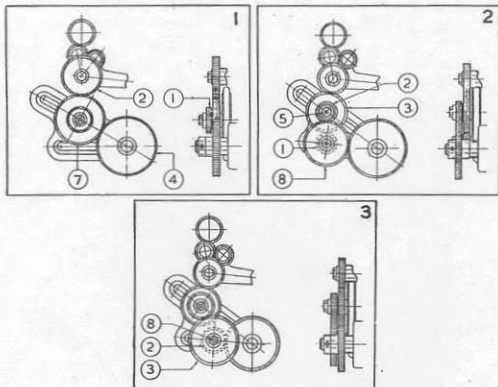

Fig. 36

MYFORD ML7 3½" CENTRE LATHE

INCH PITCHES

T P I	FEED PER REV	DRIVER	1ST STUD		2ND STUD		LEAD SCREW	SET - UP
			DRIVEN	DRIVER	DRIVEN	DRIVER		
.8	.250	20	IDLE	75 WHEEL			20	
9		40	IDLE	60 WHEEL			45	
10	1000	40	IDLE	60 WHEEL			50	
1	0909	40	IDLE	60 WHEEL			55	
2	0833	40	IDLE	50 WHEEL			60	
4	0714	20	IDLE	70 WHEEL			35	
6	0625	20	IDLE	70 WHEEL			40	
8	0556	20	IDLE	70 WHEEL			45	
9	0526	40	3B	20	IDLE	55 WHEEL	50	2
20	0500	20	IDLE	70 WHEEL			50	
22	0455	20	IDLE	70 WHEEL			55	
24	0417	20	IDLE	70 WHEEL			60	
25	0400	40	50	30	IDLE	45 WHEEL	75	2
26	0385	20	IDLE	70 WHEEL			65	
28	0357	30	35	20	IDLE	50 WHEEL	60	2
32	0313	30	40	20	IDLE	55 WHEEL	60	2
36	0278	30	45	20	IDLE	55 WHEEL	60	2
40	0250	30	50	20	IDLE	55 WHEEL	60	2
44	0227	20	55	30	IDLE	50 WHEEL	60	2
46	0217	20	46*	30	IDLE	45 WHEEL	75	2
48	0208	20	60	35	IDLE	45 WHEEL	70	2
52	0192	20	50	25	IDLE	55 WHEEL	65	2
54	0185	20	45	20	IDLE	55 WHEEL	60	2
60	0167	20	50	25	IDLE	55 WHEEL	75	2
64	0156	35	40	20	60	30	70	3
72	0139	25	50	30	45	20	60	3
80	0125	25	50	35	70	30	75	3
88	0114	30	40	25	55	20	75	3
92	0109	20	46*	30	50	20	60	3
96	0104	30	40	20	60	25	75	3
104	0096	20	50	30	60	25	65	3
	0087	20	55	30	60	25	65	3
112	0089	25	50	30	60	20	70	3
120	0083	20	50	30	60	25	75	3
	0058	20	55	25	60	20	65	3
	0043	20	60	25	65	20	75	3
	0037	20	65	25	70	20	75	3
	0018	12*	65	20	70	20	75	3

**LEADSCREW
8 THREADS
PER INCH**

● Not a standard Gear. Available as an extra.

* 12/25 tooth Tumbler Cluster Gear (1974) available as an extra.

Fig. 37

METRIC PITCHES

FEED PER REV MILLIMETERS	DRIVER	1ST STUD		2ND STUD		LEAD SCREW	SET - UP
		DRIVEN	DRIVER	DRIVEN	DRIVER		
0.20	21*	50	30	60	21*	70	3
0.25	30	40	21	60	21	70	3
0.30	21	60	45	50	21	70	3
0.35	35	40	21	50	21	70	3
0.40	21	50	21	IDLE	60 WHEEL	70	2
0.45	46	40	21	50	21	70	3
0.50	21	50	45	40	20	60	3
0.60	21	50	45	40	30	75	3
0.70	21	50	21	IDLE	60 WHEEL	40	2
0.75	45	40	35	50	21	70	3
0.80	21	50	45	IDLE	40 WHEEL	75	2
0.90	45	25	21	40	21	70	3
1.00	45	40	21	IDLE	50 WHEEL	75	2
1.10	45	50	55	40	21	75	3
1.20	45	25	30	50	21	60	3
1.25	45	40	21	IDLE	50 WHEEL	60	2
1.30	65	25	21	40	21	70	3
1.40	45	25	35	50	21	60	3
1.50	21	50	45	IDLE	35 WHEEL	40	2
1.60	45	25	21	IDLE	55 WHEEL	75	2
1.75	45	20	35	50	21	60	3
1.80	30	40	45	25	21	50	3
2.00	60	40	21	IDLE	55 WHEEL	50	2
2.25	45	40	60	40*	21	50	3
2.50	45	30	21	IDLE	50 WHEEL	40	2
2.75	55	20	30	40	21	50	3
3.00	45	25	21	IDLE	60 WHEEL	40	2
3.50	60	20	35	40	21	50	3

The tumbler reverse lever should not be shifted during thread cutting operations, as such movement may alter the position of the headstock spindle relative to the lead-screw, thereby causing split threads.

Fig. 38

MYFORD ML7 3½" CENTRE LATHE

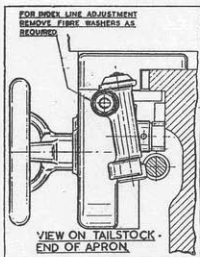

Fig. 39—Thread Dial Indicator Mounting for ML7 Lathe

Thread Dial Indicator

Every lathe is provided with a machined facing on the right hand side of the saddle, drilled and tapped ready to receive this unit. Provision is made for the alignment of the dial markings with the zero mark on the indicator body as shown in Fig. 39. The indicator can be readily engaged or disengaged, and operates as follows:—

- (1) For even number threads the clasp nut can be engaged at any numbered mark on the dial.
- (2) Odd number threads should always be engaged at the same number or any alternate number.
- (3) For half threads per inch, always engage the same number.
- (4) For other threads, m/m sizes, etc., it is recommended that the clasp nut should not be disengaged.

Note. Threads that are exact multiples of the leadscrew pitch (8 T.P.I.) do not require the use of an indicator.

Carriage Controls

Fig. 40, gives the names and positions of the carriage controls. The apron handwheel moves the carriage along the bed, and the cross slide and top slide ball handles move the toolpost in and out.

Both cross slide and top slide feedscrew dial graduations represent slide movement in increments of .001".

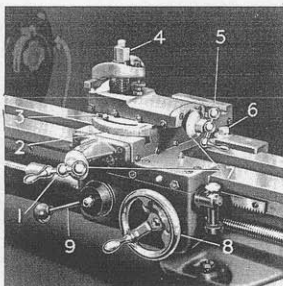

Fig. 40. Showing the carriage controls.

- | | |
|-----------------------------|---------------------------|
| (1) CROSS SLIDE BALL HANDLE | (5) TOP SLIDE BALL HANDLE |
| (2) SWIVEL GRADUATIONS | (6) SADDLE CLAMP |
| (3) LOCKING BOLT | (7) MICROMETER DIALS |
| (4) TOOL POST | (8) APRON HANDWHEEL |
| (9) HALF NUT LEVER | |

MYFORD ML7 3½" CENTRE LATHE

A clamp screw is provided on the saddle to lock the carriage to the bed for facing, parting off, and milling etc., CARE SHOULD BE TAKEN TO SEE THAT THE CLAMP SCREW IS NOT TIGHTENED WHEN THE CARRIAGE IS TRAVERSED BY THE LEADSCREW.

Longitudinal Feed

Depress the half-nut lever to engage the half nuts with the leadscrew when longitudinal movement of the carriage is required.

If the half-nuts do not engage immediately, DO NOT USE FORCE. Wait until the leadscrew rotates to a position which permits engagement of the half-nuts by gentle pressure only.

The thread dial indicator will give visual guidance and show when the leadscrew is in the correct position for nut engagement.

Saddle and Slide Rests

All slides are provided with normal gib adjustment, and steel plates are fitted beneath the saddle to prevent saddle lift. These plates bear on the underside of the lathe bed and adjustment to ensure close contact is by means of laminated shims similar to those used for the headstock bearings. The same procedure is adopted when adjustment becomes necessary.

The saddle and compound slides on a centre lathe are designed to withstand the cutting force of the tool and it is therefore necessary to maintain, by periodic adjustment, the close contact of gib strip and slide surface. Careful attention should be given to the screw adjustment to ensure an even pressure of the gib strip.

When stripping the compound slides for thorough cleaning and lubrication re-adjust the slides without feed screws and screw support brackets, testing the slides by hand motion, re-assembling the feed screw units as the last operation. By the very fact that the slides are built upon each other deflection of the turning tool is transmitted through the slides; so it is important to see that your lathe tool has the minimum overhang and is flat on its clamping surface.

Saddle Gib Strip Adjustment

When adjusting the saddle gib strip, first adjust the two outer screws, ensuring equal pressure. After tightening the locknuts, check for freedom of movement but without play. Next, adjust the inner screws, so that they contact the strip without increasing the friction and tighten their locknuts.

Apron

The apron is anchored to the saddle by means of four socket head screws, and a periodic check should be made to ensure that these screws are tight.

The 2 B.A. x 1½" cap screw (parts list, L14) must be so adjusted that the leadscrew nut will not close sufficiently to cause it to bind on the leadscrew.

The Tailstock

The Tailstock is securely locked to the bed by the quick-acting clamp lever which is located at the rear of the tailstock, Fig. 41.

The barrel is locked in place by means of the thumb lever, also at rear.

The Tailstock can be set-over $\frac{7}{16}$ " for taper turning, by first loosening the bed clamp and then adjusting the screws which are located in the tailstock body, directly above the base tenon. A zero mark is engraved at the end of the tailstock to serve as a rough guide to set-over amounts, and to assist in returning the tailstock to its normal position for parallel turning.

Tailstock Gib Adjustment

Release gib securing screws and retighten until just nipped.

Adjust thrust screws just sufficiently to remove all trace of play of the tailstock relative to the bed shears, but without causing undue friction.

Retighten gib securing screws and check for freedom of movement but lack of "play".

MYFORD ML7 3½" CENTRE LATHE

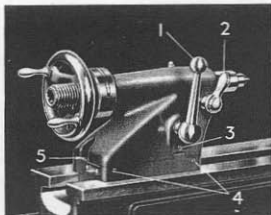

Fig. 41. Rear view of the tailstock.

- | | |
|--------------------|-------------------------|
| (1) CLAMP LEVER | (4) GIB THRUST SCREWS |
| (2) THUMB LEVER | (5) GIB SECURING SCREWS |
| (3) SET OVER SCREW | |

Tri-Leva Speed Selector

Belt tension is covered in two ways. All three belts may be adjusted simultaneously by means of the adjusting screws on the cam shaft (as for the basic machine). These should be adjusted to bring the swing head in a position approximately in the centre of the main frame clearance aperture. For individual belt adjustment remove the four screws securing the front plate and detach the plate; see left hand illustration below. The adjusting screws (1) are slotted so that they remain locked in the set position.

To adjust, push the pulley supporting arm (2) inwards to clear the adjusting screw (1), to enable the latter to be turned. The belts should be tensioned to such a degree that there is no feeling of force when the lever is depressed into the operating position.

Trip Adjustment. If an engaged lever is not tripped when a further lever is depressed, the trip plate setting may be varied by raising or lowering the pivot arms (1); see right hand illustration below. Partially release the socket set screw (4) and release locknuts (3). Alter the setting of the stop screws, testing the trip before finally locking the locknuts and the socket set screw (4).

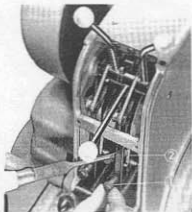

Fig. 41a

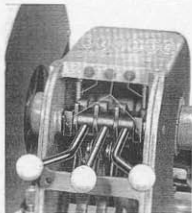

Fig. 41b

CHUCK FITTING

- (1) Before screwing backplate on to spindle nose, ensure the cleanliness of spindle nose, backplate register, faces and thread.
- (2) Screw backplate firmly on spindle nose.
- (3) Machine register diameter to light tap fit in chuck body.

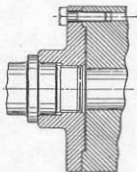

Fig. 42

Note. With three-jaw gear scroll chucks, contact is made with the outer face of the chuck body and clearance with the inner face, see Fig. 42.

With four-jaw independent chucks, contact is made with the inner face of the chuck body, see Fig. 43.

With 6" four-jaw independent chucks contact is also made with the inner face of the chuck body but the threaded portion of the backplate is housed in the chuck body to eliminate chuck overhang, see Fig. 44.

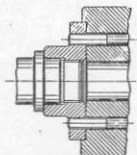

Fig. 43

- (4) Remove backplate from spindle nose. Mark out and drill clearance holes for three-jaw chuck locking bolts, and core diameter tapping holes for four-jaw chuck locking bolts. Remove all burrs with counter-sink or scraper. Care should be taken when marking out the holes to ensure clearance between the bore of the hole and bolt stem. With the four-jaw chuck backplate, the drilling centres can easily be marked by means of a centre punch with the shank diameter acting as a guide through the chuck body holes. After centring one hole, drill, tap and lock the backplate lightly with a locking bolt. The other three holes can then be centred without fear of the backplate shifting.
- (5) When tightening locking bolts, apply pressure evenly and gradually to all four in rotation.

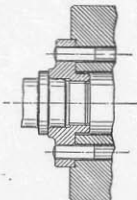

Fig. 44

CHUCK BACKPLATES & THREADED BODY CHUCKS

Register bores are held to very close limits. When backplates or threaded body chucks are supplied as separate units after the machine has left these works the register bore may need very light scraping or polishing with fine emery cloth.

Do not screw equipment on to the spindle nose without ensuring that the spindle register diameter is lightly smeared with fine oil.

INSTRUCTIONS FOR ORDERING REPLACEMENT PARTS

The following information should be supplied with the order:—

1. Type and Serial Number of the lathe, and in the case of lathes with gearboxes fitted, also the serial number of the gearbox. For location of numbers see Figs. 45 and 46.
2. Section letter and item number of part as listed.
3. Quantity Required.

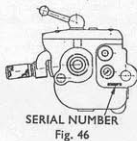
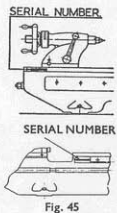

As it is the Company's policy to improve its products whenever opportunity occurs, designs are liable to modification at any time. In some cases, due to the nature of the part, it will be necessary for us to supply additional related parts, particularly if the item required has been altered.

MYFORD ML7 3½" CENTRE LATHE

INSTRUCTIONS POUR LES COMMANDES DE PIECES DE RECHANGE

Les indications ci-après sont à fournir avec la commande:

1. Type et numéro de série du tour, et, pour les tours équipés de boîtes de vitesses, également le numéro de série de cette boîte.
Pour l'emplacement de ces nombres, voir fig. 45 et 46.
2. La lettre de la section de classification ainsi que le numéro de référence de la pièce, extrait du tableau.
3. Quantité désirée.

La politique de la Société visant toujours à l'amélioration des pièces chaque fois que l'occasion s'en présente, les dessins sont susceptibles de subir des modifications à tout instant. Dans certains cas, et en raison de la nature de la pièce, il sera nécessaire que nous fournissions des pièces supplémentaires, notamment si la pièce demandée a subi des modifications.

SERIAL NUMBER

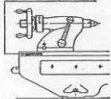

SERIAL NUMBER

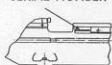

Fig. 45

INSTRUKTION FÜR DAS BESTELLEN VON ERSATZTEILEN

Eine Bestellung über Ersatzteile soll folgende Angaben enthalten:

1. Typ und Serien-Nummer der Drehbank, und in denjenigen Fällen wo die Drehbänke bereits mit Schnellwechselladungen ausgestattet sind, auch die Serien-Nummern derselben.
Wie die Nummern zu finden sind, zeigen Abb. 45 und 46.
2. Buchstabe der Schnittzeichnung und die in der Liste eingetragene Nummer des Ersatzteils.
3. Benötigte Anzahl.

Da das MYFORD-Werk jede Gelegenheit ergreift Seine Produkte den neuesten Anforderungen der Technik anzupassen, unterliegen die Zeichnungen stetigen Änderungen. Je nach der Art des Stückes kann es in speziellen Fällen unumgänglich sein, dass zusätzliche, ähnliche Ersatzteile geliefert werden müssen, besonders dann, wenn das verlangte Stück geändert wurde.

INSTRUCCIONES PARA PEDIR PIEZAS DE REPUESTO

La información siguiente debe acompañar al pedido:

1. Tipo y número de serie del torno, y en el caso de torno dotado de caja de cambio, incluir también el número de la misma.
Para localizar los números véanse las figuras 45 y 46.
2. Letra de la sección correspondiente del diagrama y número de referencia de la pieza, según está clasificada.
3. Cantidad requerida.

Como es norma de la Compañía el mejorar sus productos en toda ocasión que se requiera, el diseño está sujeto a modificaciones en cualquier momento. En algunos casos, debido a la naturaleza de la pieza, será necesario que suministremos partes anexas adicionales particularmente si la pieza ha sido modificada.

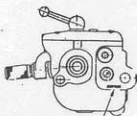

SERIAL NUMBER

Fig. 46

INSTRUÇÕES PARA ENCOMENDAR PECAS DE SUBSTITUIÇÃO

Com a encomenda devem ser dadas as seguintes informações:

1. Tipo e número de série do Torno, e, em casos de tornos com caixa de velocidades adaptada, indicar também o número de série da caixa de velocidades.
Para encontrar os números ver as figuras 45 e 46.
2. Letra do corte esquemático e número de ordem da peça conforme relação.
3. Quantidade necessária.

Como é norma da Firma melhorar os seus productos sempre que se proporcione ocasião, os desenhos estão sujeitos a modificação em qualquer altura. Em alguns casos, devido à natureza da peça, ser-nos-á necessário fornecer peças adicionais, especialmente se o artigo requerido tiver sido modificado.

A

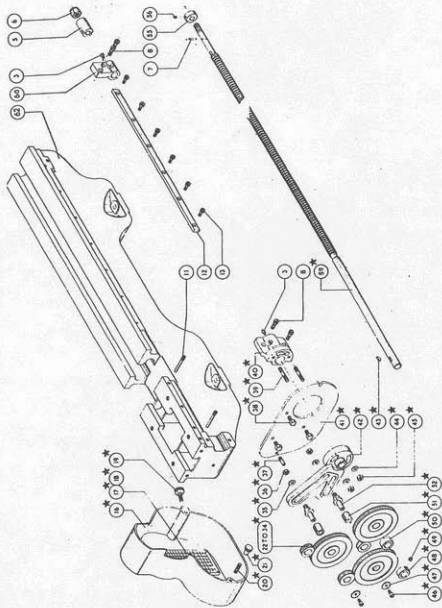

BED, LEADSCREW AND GEAR TRAIN ASSEMBLY

SECTION A

BED, LEADSCREW and GEAR TRAIN ASSEMBLY

Drq. Ref.	Part No.	Description	No. Off/Mc.	Drq. Ref.	Part No.	Description	No. Off/Mc.
A3	65000	Oil Nipple (2 B.A.)	2	A37	70/11326	Stud	3
A5	70/11113	Distance Collar	1	A38	100309	Hexagon Head Set Screw (½" B.S.F. x ½")	3
A6	100308	"Simmonds" Nut (½" B.S.F.)	1	A39	A4725	Stud	2
A7	70/11114	Pin	1	A40	70/1134/1	L.H. Leadscrew Bracket Assembly	1
A8	100307	Cap Screw (½" B.S.F. x ½")	4	A41	70/1105/2	Change Gear Guard Backplate	1
A11	A2137	Thrust Screw	2	A42	A4736	Change Gear Quadrant Assembly	1
A12	70/1112/1	Rack	1	A43	70002	Woodruff Key No. 404	1
A13	100026	Cap Screw (2 B.A. x ½)	6	A44	100005	Washer (½")	2
A16	70/1106/2	Change Gear Guard	1	A45	100057	Hexagon Nut (½" B.S.F.)	2
A17	A2639	Screwcutting Chart	1	A46	100018	Cheese Head Screw (2 B.A. x ½)	2
A18	100241	Rivets (No. 0 x ⅝)	6	A47	11287	Washer	2
A19	70/11131	Thumb Screw	1	A48	11286	Collar	1
A20	A4726	Stud	1	A49	11278	Grubscrew	1
A21	70/1909	Thumb Nut	1	A50	70/1132	Spacer	1
A22	11285	20T Change Gear	2	A51	A1644	Change Gear Bush	2
A23	11285	25T Change Gear	1	A52	70/1107	Change Gear Stud	2
A24	11285	30T Change Gear	1	A55	70/1115/1	Thrust Collar	1
A25	11285	35T Change Gear	1	A56	100011	Socket Setscrew (½" B.S.F. x 1) (Cup Point)	1
A26	11285	38T Change Gear	1	A59	A2054/2	Leadscrew	1
A27	11285	40T Change Gear	1	A60	70/1135/2	R.H. Leadscrew Bracket Assembly	1
A28	11285	45T Change Gear	1	A62	A8724/1	Bed	1
A29	11285	50T Change Gear	1				
A30	11285	55T Change Gear	1				
A31	11285	60T Change Gear	1				
A32	11285	65T Change Gear	1				
A33	11285	70T Change Gear	1				
A34	11285	75T Change Gear	1				
A35	100008	Washer (½")	2				
A36	100032	Hexagon Nut (½" B.S.F.)	2				

*These parts do not apply to ML7B Quick Change Lathes.

†A12 For longbed lathe A3470

†A13 For longbed lathe 10 off

†A39 For longbed lathe A3472/1

†A62 For longbed lathe A8779/1

B

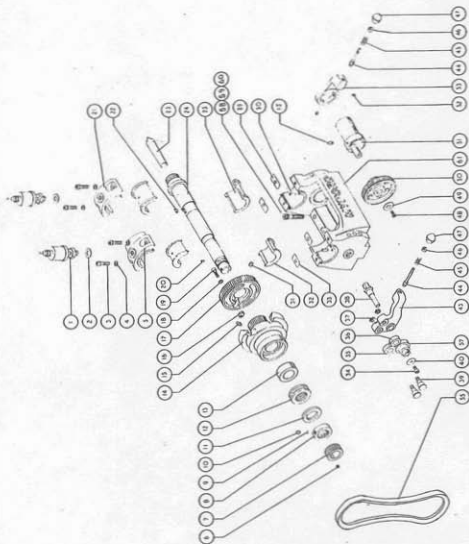

HEADSTOCK ASSEMBLY

SECTION B
HEADSTOCK ASSEMBLY

Dwg. Ref.	Part No.	Description	No. Off/Mc.	Dwg. Ref.	Part No.	Description	No. Off/Mc.
B1	65174	Sight-feed Lubricator	2	B31	100011	Socket Set Screw (1/8" B.S.F. x 1/4") (Cup Point)	1
B2	11261	Fibre Washer (1/8" B.S.P.)	4	B32	70/1206	Spindle Bearing (Rear)	1
B3	100314	Cap Screw (1/8" B.S.F. x 1/4")	4	B33	70/1204	Laminated Shim (Rear Bearing)	2
B4	70/1984	Washer	4	B34	100018	Cheese Head Screw (2 B.A. x 1/4")	1
B5	70/1202	Bearing Cap (Rear)	1	B35	70/1242	18T Tumbler Gear	1
B6	MY2820	Grubscrew (2 B.A. x 1/8")	1	B36	70/1241	18T Tumbler Gear	1
B7	70/1246	25T Gear	1	B37	100305	Hexagon Locknut (1/8" B.S.F.)	2
B8	70/1239	Locking Collar	1	B38	70/1222	Tumbler Reverse Stud	1
B9	11253	Copper Pad	1	B39	70/1243	Gear Stud	2
B10	100108	Socket Set Screw (1/8" B.S.F. x 1/8") (Half Dog Point)	1	B40	11287	Washer	1
B11	MF5911	Thrust Washer	1	B43	70/1208	Tumbler Reverse Lever	1
B12	73044	Thrust Bearing	1	B44	70/1219	Plunger	2
B13	70/1240	Distance Sleeve	1	B45	A4728	Spring	2
B14	70/1234	Van Cone Pulley Assembly	1	B46	70/1220	Screwed Bush	2
B15	63000	Oil Nipple (2 B.A.)	2	B47	90031	Acorn Knob	2
B16	70/1227	Backgear Key	1	B48	100405	Socket Countersunk Screw (2 B.A. x 1/4")	1
B17	70/1209	65T Backgear	1	B49	70/1217	Washer	1
B18	100022	Washer (1/8")	1	B50	70/1218	21/56T Backgear Cluster	1
B19	100023	Cap Screw (2 B.A. x 1/4")	1	B51	A1856	Backgear Eccentric Assembly	1
B20	70/1231	Pin	1	B52	100322	Socket Set Screw (2 B.A. x 1/4") (Cup Point)	2
B21	70/1201	Bearing Cap (Front)	1	B53	70/1207/1	Backgear Lever	1
B22	70002	Woodruff Key (No. 404)	1	B55	70020	Van Bolt (Headstock) (23" Inside Length)	1
B23	70/1249	60° Centre (soft)	1	B57	70/1232/1	Tumbler Sleeve Gear	1
B24	70/1230	Spindle	1	B58	100554	Cap Screw (M8 x 1.25 x 35 mm)	2
B25	70/1205	Spindle Bearing (Front)	1	B59	100234	Cap Screw (M8 x 1.25 x 30 mm)	1
B26	70/1203	Laminated Shim (Front Bearing)	1	B60	100253	Cap Screw (M8 x 1.25 x 25 mm)	1
B29	70/1228	Pin	2	B61	70/1211/4	Headstock	1

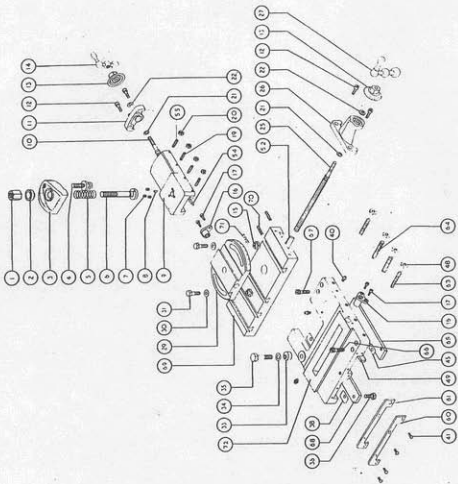

CARRIAGE ASSEMBLY

C

SECTION C
CARRIAGE ASSEMBLY

Part No.	Description	Part No.	Description	No. Off/Mc.	No. Off/Mc.
C1 7011412	Hexagon Nut	C31 A7742	Hexagon Head Bolt	2	
C2 7011410	Spherical Washer	C33 701312	Clamp Eccentric	1	
C3 7011409/1	Tool Clamp	C34 100008	Washer (1/8")	1	
C4 7011413	Adjusting Screw Assembly	C35 11296	Hexagon Head Bolt (1/8" B.S.F. x 1/4") (Hard)	1	
C5 A2806	Spring	C36 100315	Hexagon Head Set Screw (1/8" B.S.F. x 1/4")	3	
C6 7011406	Tool Clamp Stud	C38 701304	Laminated Shim (Rear)	3	
C7 11264	Grubscrew	C40 65000	Oil Nipple (2 B.A.)	3	
C8 7011411	Pin	C41 100316	Round Head Screw (4 B.A. x 1/4")	4	
C9 7011403	Top Slide	C45 701305	Laminated Shim (Front)	2	
C10 7011408	Top Slide Feedscrew	C48 100305	Hexagon Locknut (1/8" B.S.F.)	4	
C11 7011401	End Plate	C49 701319/1	Saddle Gib Strip	1	
C12 100023	Cap Screw (2 B.A. x 1/4")	C52 701320/3	Cross Slide Gib Strip	1	
C13 701303	Micrometer Dial	C54 701405/2	Top Slide Gib Strip	1	
C14 11293	Top Slide Ball Handle Assembly	C55 11270	Gib Strip Adjusting Screw	2	
C15 A1845	Tea Nut	C60 A8736	Wiper Housing	2	
C16 701302	Feed Nut	C61 A8735	Wiper	1	
C17 100317	Cheese Head Screw (4 B.A. x 1/4")	C63 A7760	Adjusting Screw	3	
C19 11269	Gib Adjusting Screw	C64 A7424/1	Adjusting Screw	1	
C20 100027	Hexagon Locknut (2 B.A.)	C65 A2065	Saddle Strip (Front)	1	
C21 7011984A	Washer (Hard)	C66 100313	Cap Screw (1/8" B.S.F. x 1/4")	1	
C22 11257	Fibre Washer	C67 100314	Cap Screw (1/8" B.S.F. x 1/4")	1	
C25 701321	Cross Slide Feedscrew	C68 A2122	Saddle Strip (Rear)	1	
C26 701301	End Plate	C69 701308/1	Cross Slide	1	
C27 701337	Cross Slide Ball Handle Assembly	C70 A8623	Socket Setscrew (Wedglok)	6	
C29 A8079	Top Slide Base Assembly	C71 100318	Socket Setscrew (M5 x 20 mm) (Dog Point)	2	
C30 100005	Washer (1/8")	C72 A8734/1	Saddle	1	
C10 A2282/1	Top Slide Feedscrew Assembly	C26 A1384	Cross Slide End Place	1	
C11 A1649/1	Top Slide End Place	C27 A2073	Cross Slide Ball Handle Assembly	2	
C12 A3249	Top Slide Micrometer Dial	A2058	Diaphragm Washer	2	
C13 A3250/1	Cross Slide Micrometer Dial	A1541/1	Screw - Ball Handle Securing	2	
C14 A2093	Top Slide Ball Handle Assembly	A2229	Adjusting Collar	2	
C16 A1648	Feed Nut (Top and Cross Slides)	11253	Copper Pad	2	
C25 A2636	Cross Slide Feedscrew Assembly		Socket Setscrew (1/8" B.S.F. x 1/4") (Half Dog Point)	2	

† For machines having metric feedscrews with 80 and 40 division dials the following are used:

ER

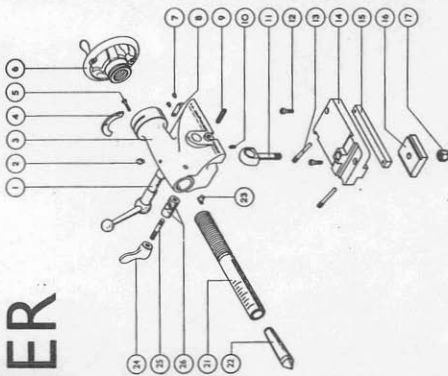

TAILSTOCK ASSEMBLY

L

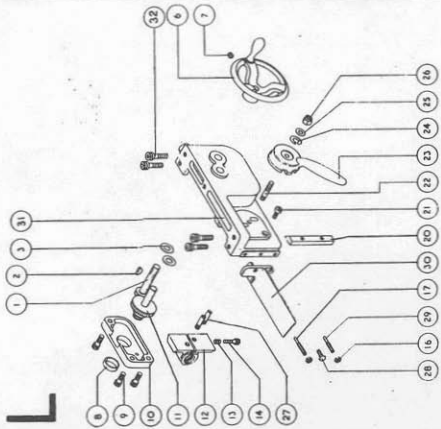

APRON ASSEMBLY

SECTION ER

TAILSTOCK ASSEMBLY

Qty. Ref.	Part No.	Description	No. Off/Mc
ER1	A2138	Eccentric and Lever Assembly	1
ER2	65000	Oil Nipple (2 B.A.)	1
ER3	A2797	Tailstock Body	1
ER4	70/1509	Thrust Plate	1
ER5	100037	Round Head Screw (4 B.A. x 1")	1
ER6	70/1520	Handwheel Assembly	2
ER7	100038	Rivets (No. 4 x 1/8")	1
ER8	11301	Graduated Plate	2
ER9	A2146	Adjusting Screw	1
ER10	A2139	Eccentric Locating Screw	1
ER11	A2140	Eye Bolt	1
ER12	100023	Cap Screw (2 B.A. x 1")	2
ER13	A2137	Thrust Screw	1
ER14	A2099	Tailstock Base	1
ER15	A2136	Gub Strip	1
ER16	70/1514	Clamp Plate	1
ER17	100284	'Simmonds' Nut (1/2" B.S.F.)	1
ER21	A2798	Barrel	1
ER22	70/1248	60° Centre (Hard)	1
ER23	70/1506	Barrel Key	1
ER24	70/1507/1	Pad Bolt and Bush	1
ER25	13355	Stud	1
ER26	13354	Barrel Locking Lever	1

SECTION L
APRON ASSEMBLY

Qty. Ref.	Part No.	Description	No. Off/Mc
L1	A2086	Hand Traverse Pinion	1
L2	70002	Woodruff Key No. 404	2
L3	11260	Fibre Washer	1
L6	A2087	Handwheel Assembly	1
L7	100011	Socket Set Screw (1/2" B.S.F. x 1/2") (Cup Point)	3
L8	73001	'Ollite' Bush (1 1/2 x 1 1/2)	1
L9	100307	Cap Screw (1/2" B.S.F. x 1")	1
L10	70/1340	Gear Cover Assembly (Includes L8)	1
L11	A2085	Rack Pinion Assembly	1
L12	A1975/2	Leadscrew Nut	1
L13	A4779	Spring	1
L14	100319	Cap Screw (2 B.A. x 1 1/2")	2
L16	100027	Hexagon Locknut (2 B.A.)	1
L17	A9337	Gib Adjusting Screw	2
L20	A2082	Gib Strip	1
L21	A2147	Gib Securing Screw	1
L22	11295	Stud	1
L23	A1837/1	Cam Lever	1
L24	100053	Spring Washer	1
L25	100005	Washer (1")	1
L26	100030	'Simmonds' Nut (1/2" B.S.F.)	1
L27	70/1326	Cam Peg	2
L28	100320	Hexagon Head Set Screw (2 B.A. x 1")	1
L29	A9338	Gib Adjusting Screw	1
L30	A4188/1	Leadscrew Guard	1
L31	A2081/2	Apron	1
L32	100257	Cap Screw (M6 x 1 x 25 mm)	4

MYFORD ML7 3 1/2" CENTRE LATHE

F

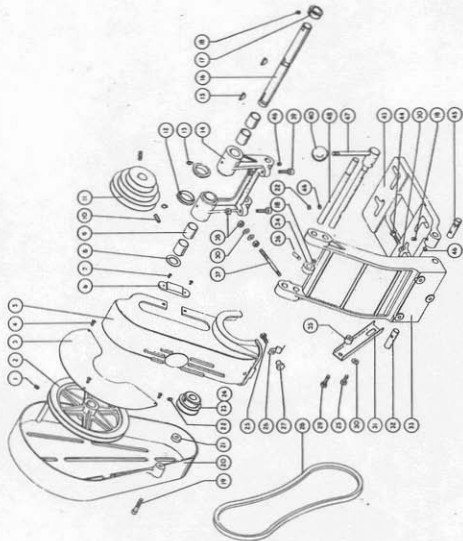

MOTORISING ASSEMBLY

SECTION F MOTORISING ASSEMBLY

Drif. Ref.	Part No.	Description	No. Off/Mc.	Drif. Ref.	Part No.	Description	No. Off/Mc.
F1	100010	Socket Set Screw (1/8" B.S.F. x 1/4") (Cup Point)	2	F26	70/1625	Spring Clip	1
F2	A1832	Countershaft Pulley	1	F27	70/1624	Knob	1
F3	70/1628	Cover Plate	1	F28	70025	Vee Belt (Motor Drive) (34" x 5" Inside Length) ...	1
F4	100406	Countersunk Head Screw (2 B.A. x 1/4")	3	F29	100310	Hexagon Head Set Screw (1/8" B.S.F. x 1/4")	6
F5	70/1621/1	Headstock Belt Guard	1	F30	100005	Washer (1/2")	1
F6	70/1627	Guard Retaining Plate	2	F31	A1859	Tie Bar	1
F7	100556	Countersunk Head Screw (4 B.A. x 1/4")	4	F32	A1843	Motor Base Swing Pin	1
F8	A1973	Thrust Washer	1	F33	70/1602/3	Countershaft Arm	1
F9	A2834/1	'Ollite' Bush	1	F34	70/1612	Eccentric Shaft Collar	1
F10	100043	Socket Set Screw (1/8" B.S.F. x 1/4") (Cup Point)	2	F35	A1862	Tie Bar Spacer	1
F11	70/1626/3	Vee Cone Pulley	2	F36	70/1326	Stop Peg	1
F12	A1227	Hard Rubber Bush	2	F37	A4727	Stud	1
F13	65000	Oil Nipple (2 B.A.)	2	F38	100057	Hexagon Nut (1/8" B.S.F.)	4
F14	70/1631/2	Swing Head Assembly (Includes F9)	2	F39	A2123	Adjusting Screw	2
F15	70003	Woodruff Key (No. 606)	1	F40	80003	Knob (1/2" Dia. x 1/8" B.S.W.)	1
F16	70/1619/2	Countershaft	1	F43	70/1604/1	Motor Base	1
F17	MA6001	Countershaft Collar	1	F44	100520	Hexagon Head Set Screw (1/8" B.S.F. x 1/4")	3
F18	100011	Socket Set Screw (1/8" B.S.F. x 1/4") (Cup Point) ...	1	F45	A1842	Motor Base Swing Pin	1
F19	100313	Cap Screw (1/8" B.S.F. x 1/4")	4	F46	100327	Socket Set Screw (1/8" B.S.F. x 1/8") (Half Dog Point)	3
F20	70/1622	Countershaft Belt Guard	1	F47	70/1613/1	Eccentric and Lever Assembly	1
F21	70/1983/1	Belt Guard Spacer	1	F48	A3969	Swing Head Pin	1
F22	100046	Socket Set Screw (1/8" B.S.F. x 1/8") (Cup Point) ...	2				
F23	A1852/1	Motor Pulley (1/2" Bore)	1				
*F24	A1851/1	Motor Pulley (1/2" Bore)	1				
F25	100315	Hexagon Head Set Screw (1/8" B.S.F. x 1/4")	2				

*Standard bore size - other bores available - stated exact size required when ordering.

P

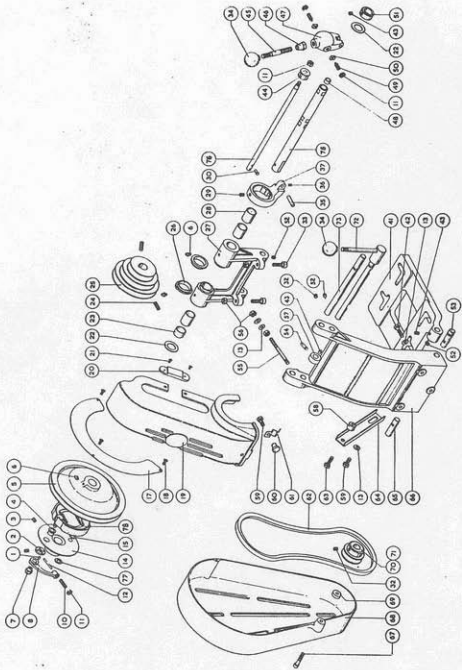

MOTORISING AND I466 CLUTCH ASSEMBLY

SECTION P

MOTORISING AND I466 CLUTCH ASSEMBLY

MYFORD ML7 3/4" CENTRE LATHE

Dr. Ref.	Part No.	Description	No. Off/Mc.	Dr. Ref.	Part No.	Description	No. Off/Mc.
P1	A1956	Pin	1	P33	A1843	Motor Base Swing Pin	3
P2	A1795	Adjusting Washer	1	P34	70/1326	Stop Peg	1
P3	100512	Socket Set Screw (1/8" B.S.F. x 1/4") (Cup Point)	2	P35	A4727	Stud	1
P4	A1792	Bush	1	P36	100057	Hexagon Nut (1/8" B.S.F.)	4
P5	A1789/1	Countershaft Pulley	1	P37	70/1612	Eccentric Shaft Collar	1
P6	65000	Oil Nipple (2 B.A.)	3	P38	A1862	Tie Bar Spacer	2
P7	A1953	Sleeve Nut	2	P39	100315	Hexagon Head Set Screw (1/8" B.S.F. x 1/4")	2
P8	A1958	Cam Lever Assembly (Includes P1)	1	P40	70/1624	Knob	1
P9	A1797	Adjusting Screw	1	P41	70/1625	Spring Clip	1
P10	100305	Hexagon Locknut (1/8" B.S.F.)	4	P42	70025	Hex Belt (Motor Drive) (34.5" Inside Length)	1
P11	A1803	Operating Rod	1	P43	100310	Tie Bar	1
P12	100005	Washer (1/2")	6	P44	A1859	Motor Base Swing Pin	1
P13	A9951	Backplate Assembly (Includes P4)	1	P45	A1843	Motor Base Swing Pin	1
P14	A1952	Shim	1	P46	70/1602/5	Countershaft Arm	1
P15	A1952	Shim	1	P47	100313	Cap Screw (1/8" B.S.F. x 1/4")	1
P16	A2095	Cover Plate	1	P48	70/1622	Countershaft Belt Guard	1
P17	A2096	Countersunk Head Screw (2 B.A. x 1/4")	3	P49	70/1983/1	Belt Guard Spacer	1
P18	100406	Countersunk Head Screw (2 B.A. x 1/4")	3	P50	A1852/1	Motor Pulley (1/8" Bore)	1
P19	70/1621/1	Headstock Belt Guard	2	P51	MA6001	Motor Pulley (1/8" Bore)	1
P20	70/1627	Guard Retaining Plate	2	P52	100327	Eccentric and Lever Assembly	1
P21	100556	Countersunk Head Screw (4 B.A. x 1/4")	4	P53	A1800/1	Swing Head Pin	1
P22	A1973	Thrust Washer	2	P54	A3969	Countershaft Assembly (Includes P48)	1
P23	A9943	'Ollite' Bush	1	P55	A1800/1	Actuating Shaft	1
P24	100043	Socket Set Screw (1/8" B.S.F. x 1/4") (Cup Point)	2	P56	70019	Brake Shoe Assembly not available - state exact size required	1
P25	70/1626/3	Yee Cone Pulley	2	P57	100327	Standard bore size - other bores available - state exact size required	1
P26	A1227	Hard Rubber Bush	2	P58	70019	Standard bore size - other bores available - state exact size required	1
P27	A4732	Swing Head Assembly (Includes P23 and P28)	2	P59	70019	Standard bore size - other bores available - state exact size required	1
P28	A2834/1	'Ollite' Bush	3	P60	70019	Standard bore size - other bores available - state exact size required	1
P29	100010	Socket Set Screw (1/8" B.S.F. x 1/4") (Cup Point, Wedglok)	1	P61	70019	Standard bore size - other bores available - state exact size required	1
P30	A1801	Stop Pin	1	P62	70019	Standard bore size - other bores available - state exact size required	1
P31	100046	Socket Set Screw (1/8" B.S.F. x 1/4") (Cup Point)	2	P63	70019	Standard bore size - other bores available - state exact size required	1
P32	A2123	Adjusting Screw	2	P64	70019	Standard bore size - other bores available - state exact size required	1
P33	80003	Knob (1 1/2" Dia. x 1/8" Whitworth)	2	P65	70019	Standard bore size - other bores available - state exact size required	1
P34	A1807	Pivot Pin	2	P66	70019	Standard bore size - other bores available - state exact size required	1
P35	100036	Socket Set Screw (2 B.A. x 1/4") (Cup Point)	1	P67	70019	Standard bore size - other bores available - state exact size required	1
P36	A1805	Lever Pivot Bracket	1	P68	70019	Standard bore size - other bores available - state exact size required	1
P37	A1805	Lever Pivot Bracket	1	P69	70019	Standard bore size - other bores available - state exact size required	1
P38	70/1604/1	Motor Base	1	P70	70019	Standard bore size - other bores available - state exact size required	1
P39	100520	Hexagon Head Set Screw (1/8" B.S.F. x 1/4")	3	P71	70019	Standard bore size - other bores available - state exact size required	1
P40	100011	Socket Set Screw (1/8" B.S.F. x 1/4") (Cup Point)	4	P72	70019	Standard bore size - other bores available - state exact size required	1

S

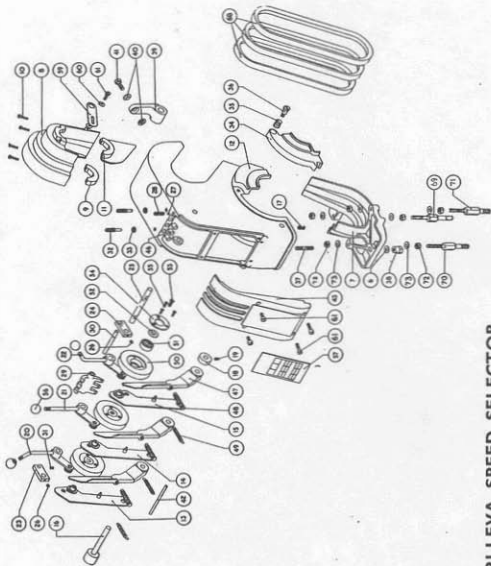

20/034 TRI-LEVA SPEED SELECTOR

SECTION S

20/034 TRI-LEVA SPEED SELECTOR

Dwg. Ref.	Part No.	Description	No. Off/Mc.	Dwg. Ref.	Part No.	Description	No. Off/Mc.
S6	100005	Washer (1/2")	1	S37	A3496	Stud	1
S7	A3477/1	Base	1	S38	C1241	Nut	1
S8	A3478	Belt Trap (Countershaft)	1	S39	A3497	Support Bracket	2
S9	A3479	Clamp (Countershaft L.H. End)	1	S40	A3498	Spherical Washer	1
S10	100545	Clamp (Countershaft R.H. End)	4	S41	100083	Hexagon Head Set Screw (1/2" B.S.F. x 1/2")	1
S11	A3480	Clamp (Countershaft R.H. End)	1	S42	A3514	Rod	1
S12	A3481	Main Frame	1	S43	A3499/1	Lever	3
S13	A4720A	Tensioning Arm Assembly (L.H. End)	1	S46	A2023	Pad	3
S14	A4720B	Tensioning Arm Assembly (Centre)	1	S47	A3500/1	Adjusting Screw	3
S15	A4720C	Tensioning Arm Assembly (R.H. End)	1	S48	A3502	Spring	3
S16	A3483	Pivot Pin (Lever Assembly)	1	S49	A3504	Pulley	3
S17	100045	Socket Set Screw (1/2" B.S.F. x 1/2") (Cup Point)	1	S50	A3505	Ball Bearing (RHP No. 629)	3
S18	A3484	Collar	1	S51	73038	Cover	3
S19	100012	Socket Set Screw (2 B.A. x 1/2") (Cup Point)	1	S52	A3507	Socket Countersunk Screw (2 B.A. x 1/2")	3
S20	A3485A	Operating Arm Assembly (L.H. End)	1	S53	100405	Retaining Ring	3
S21	A3485B	Operating Arm Assembly (Centre)	1	S54	A3781	Countersunk Head Screw (4 B.A. x 1/2")	9
S22	A3485C	Operating Arm Assembly (R.H. End)	1	S55	100397	Knob	3
S23	A3486	Radius Arm (L.H. End)	1	S56	80016	Speed Plate	1
S24	A3487	Radius Arm (R.H. End)	1	S57	A3519/1	Link	2
S25	A3488	Pivot Pin (Operating Arm Assembly)	1	S58	A3780	Washer (1/2")	2
S26	100036	Socket Set Screw (2 B.A. x 1/2") (Cup Point)	2	S60	100022	Cheese Head Screw (2 B.A. x 1/2")	5
S27	MY4402	Copper Pad	1	S61	100546	Vee Belt (23" Inside Length)	3
S28	100641	Socket Set Screw (1/2" B.S.F. x 1/2") (Half Dog Point)	1	S68	70020	Support Stud (Rear, L.H.)	1
S29	A3489	Trip Plate	1	S69	A3474/1	Support Stud (Front, L.H.)	1
S30	A3490	Pivot Pin (Trip Plate)	1	S70	A3475/1	Support Stud (Front, R.H.)	1
S31	100322	Socket Set Screw (2 B.A. x 1/2") (Cup Point)	1	S71	A3476/1	Hexagon Nut (M6 x 1 mm)	6
S32	A3491	Stop Screw	1	S72	100071	Washer (M6)	6
S33	A3492	Locknut	2	Not illustrated			
S34	A3493	Hinged Cover	1	S62	78003	Hexagon Key (3/8" A/F)	1
S35	A3494	Spring	1	S63	78020	Box Spanner (1/2" White)	1
S36	A3495	Pivot Screw	1	S64	78021	Double Ended Spanner (2 B.A. x 0 B.A.)	1

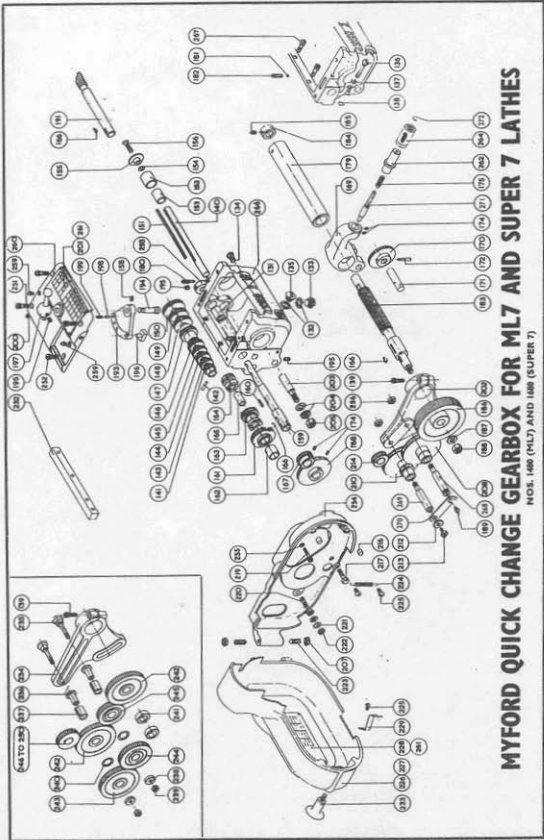

MYFORD QUICK CHANGE GEARBOX FOR ML7 AND SUPER 7 LATHES

NOS. 148 (ML7) AND 148 (SUPER 7)

MYFORD ML7 3 1/2" CENTRE LATHE

PARTS LIST FOR
QUICK CHANGE GEARBOX

Part No.	Description	Qty. Ref.	Part No.	Description	Qty. Ref.
131	Bush	164	A2307	16T Gear	4
132	Sealing Washer (Dowry Selon Mark 5)	165	A2494	Bush	3
133	Drain Plug (1" B.S.F.)	166	70002	Woodruff Key (No. 404)	
134	Oil Level Plug	167	A3013	26T Gear	
135	Plug	168	A3014	52T Gear	
136	Captive Screw	169	A2269/1	Selector	
137	Spring Washer (1" Terrys 159)	170	A2299	39T Tumbler Gear	
138	'O' Ring (Ref. B.S. 011)	171	A2296	Spindle	
139	Cap Screw (1" B.S.F. x 1/2)	172	100521	Taper Pin (No. 0 x 1 1/2)	
140	Shaft	174	100322	Socket Setscrew (2 B.A. x 1/2) (Cup Point)	
141	16T Gear	175	A2612	Spring	
142	Taper Pin (No. 0 x 1/2)	179	A3009	Guide Bar	
143	18T Gear	180	A2542	Peg End GrubscREW	
144	19T Gear	181	11253	Copper Pad	
145	20T Gear	182	100541	Socket Setscrew (1" B.S.F. x 1/2) (Half Dog Point)	
146	22T Gear	183	A3010	Input Shaft	
147	24T Gear	184	11286	Collar	
148	26T Gear	185	100011	Socket Setscrew (1" B.S.F. x 1/2) (Cup Point)	
149	28T Gear	186	A2327	72T Gear	
150	32T Gear	187	100325	Washer (1/2" B.S.F.)	
151	Key	188	100542	Hexagon Nut (1/2" B.S.F.)	
152	Bush	189	65000	Oil Nipple (2 B.A.)	
153	Clamping Sleeve	191	A3011/1	Leadscrew	
154	Laminated Washer	193	A2272	Quadrant Plate	
155	Clamp Washer	194	A2293	Pivot Pin	
156	Socket Countersunk Screw (1" B.S.F. x 1/2)	195	100046	Socket Setscrew (1" B.S.F. x 1/2) (Cup Point)	3
158	Socket Setscrew (2 B.A. x 1/2) (Cup Point)	196	A2286	Thrust Block	
159	Layshaft	197	A2511	Upper Lever	
160	Key	198	A2521	Locating Pin	
161	32T Gear	199	13529	Spring	
162	Oilite Bush	200	11278	GrubscREW	
163	24T Sliding Gear	201	A2602/2	Screwcutting Chart	

PARTS LIST FOR
QUICK CHANGE GEARBOX (contd.)

Dwg. Ref.	Part No.	Description	No. Off/Mc.	Dwg. Ref.	Part No.	Description	No. Off/Mc.
202	A2328/1	Change Gear Quadrant	1	232	A2754	Drilling Template	1
203	A3015	Anchor Pin	1	233	80004	Knob (F. W. Evans, reference No. 780)	1
204	100015	Washer (1/2" Dia.)	2	251	100307	Cap Screw (1/2" B.S.F. x 1 1/2")	3
205	100016	Hexagon Nut (1/2" B.S.F.)	2	252	100462	Cap Screw (1/2" B.S.F. x 1 1/2")	1
207	1000	Hexagon Lock Nut (1/2" B.S.F.)	2	254	A2963	Backplate	1
208	A2326/1	19/57T Reversible Cluster Gear	1	255	100072	Washer (1/2")	1
210	A2325/1	19/57T Fixed Cluster Gear	1	256	100326	Hexagon Lock Nut (1/2" B.S.F.)	2
212	11287	Washer	1	258	7011115/1	Collar	1
213	A1999	Retaining Screw	1	259	65089	Oil Nipple (Lumatic HDFV4/45)	2
214	A3115	24T Gear	1	260	A2977/2	Top Cover	1
216	A2023	Pad	2	261	100241	Rivet (No. 0 x 1/8")	8
217	100083	Hexagon Head Set Screw (1/2" B.S.F. x 1")	1	262	A2297/1	Plunger Housing	1
219	100311	Cap Screw (2 B.A. x 1")	1	264	A2519/1	Knob	1
220	A3017	Stud	1	266	A2965/2	Gearbox	1
221	100095	Washer (1/2" Dia.)	3	267	100359	Cap Screw (M6 x 1 x 20 mm)	2
222	100305	Hexagon Lock Nut (1/2" B.S.F.)	2	268	A2330/2	Gear Stud	1
223	A2024	Hinge Screw	2	269	A2329/3	Gear Stud	1
224	A2012	Tension Spring	2	270	A2331/1	Link	1
225	100007	Round Head Screw (2 B.A. x 1/8")	3	271	A2279/2	Plunger	1
226	A2527/1	Change Wheel Guard (ML7)	1	272	100132	Circlip (1400 - 6)	1
227	A2528/1	Change Wheel Guard (Super 7)	1				
228	A7934	Metric Screwcutting Chart	1	N.B.		Dowels, 268 (A2787) are fitted to R.H. leadscrew bracket, A60, on quick change lathes only	2
229	A3018	Spring Clip	1				
139	100370	Cap Head Screw (1/2" B.S.F. x 3/8")	1	242	11285	60T Change Gear	2
234	A2469	Change Gear Quadrant	1	243	11285	63T Change Gear	1
235	A1496	Change Wheel Stud	2	244	11285	50T Change Gear	2
236	A1501	Sleeve	2	245	11285	45T Change Gear	2
237	A1500	Bush	2	246	11285	28T Change Gear	1
238	A1498	Washer	2	247	11285	30T Change Gear	1
239	100057	Hexagon Nut (1/2" B.S.F.)	2	248	11285	35T Change Gear	1
240	A1499	Change Wheel Spacer	2	249	11285	40T Change Gear	1
241	A2604	Distance Piece	2	250	11285	55T Change Gear	1

METRIC CONVERSION SET

GENERAL POINTS ON CENTRE LATHE PRACTICE

- (1) Clean and oil your machine after use.
- (2) When holding work in a chuck, grip as much of the material as possible. If thin flanged work is to be held, give support to the tool thrust by inserting a ring or collar between chuck body and work piece. The pressure on the jaws can be eased and so prevent straining of the chuck to avoid what is commonly known as 'Bell Mouth jaws'.
- (3) Do not grip irregular shaped material in a three-jaw chuck. Use a four-jaw chuck for rough material.
- (4) Do not swing offset jobs on the faceplate without balancing by counterweight. A piece of shaped lead clamped to the faceplate opposite the offset material will give the necessary balance to most jobs. Swinging unbalanced work places an unnecessary load on bearings and causes ovality on work being turned.
- (5) After your work has been clamped to faceplate, pull the machine round by hand and test tool and slide clearance to avoid damage by swinging bolts, etc.
- (6) When roughing out heavy stock, use the tailstock centre for support. This helps the chuck's life of accuracy and takes away some of the load applied to spindle and bearings.
- (7) When knurling, do not force knurling tool into work with too great a pressure as strain is placed upon feedscrew and nut. Use lubricating oil freely during knurling operation.
- (8) Do not leave the key in your headstock chuck. Nasty accidents occur should the lathe be switched on accidentally.
- (9) See that the spindle thrust is correctly adjusted. Any end float causes chatter.
- (10) Always wipe spindle nose and chuck register faces clean before mounting chucks, faceplates, etc.
- (11) When removing a chuck (or faceplate), do not 'yank' the chuck off with the headstock locked with the back-gear, but set the headstock for normal back-gear drive, and after placing a piece of hard wood on the lathe bed, pull the spindle round by means of the belt so that one jaw of the chuck or slot in the faceplate strikes the wood sharply. The most obstinate chuck is released in this way, and a great deal of the load is taken from the back-gear teeth.
- (12) Always clean out the spindle taper before inserting centres.
- (13) A small mark on the headstock centre with a corresponding mark on the front face of the spindle nose enables the position of location for trueness to be maintained.
- (14) Do not forget that the headstock centre (live centre) must run true and should be turned in position when correction is necessary.
- (15) Except for occasional oiling, the tailstock requires very little attention. It is, however, important that its original accuracy is maintained. The following points will assist in avoiding unnecessary tailstock troubles:—
When turning between centres, see that the barrel is as far in the tailstock body as possible. This will give greater rigidity and lessen the load on the body bore when machining. When drilling, see that the drill starts in a truly centred hole as any swing on a fairly large drill causes unnecessary wear on the sliding barrel. When turning between centres, remember that the tailstock centre has the friction of the rotating work piece to withstand and must be kept lubricated; also that when work being turned becomes heated, it expands, giving an added pressure to the contact faces. Check your work freedom at periods during the turning operation, slightly slackening the tailstock pressure when necessary. Very little trouble should arise with 'burned up' centres if these points are watched. A hardened centre when it 'burns up' needs accurate regrinding, and often the hardened particles of steel become embedded in the work being turned, causing unlimited complications unless removed.
- (16) When setting gear trains, do not mesh the change wheels too tightly.
- (17) Always remember that your ML7 Lathe is a valuable Machine Tool, and no effort should be spared to maintain its quality and accuracy.

Myford

Popular Spare Parts For ML7 Lathes

History:

The ML7 lathe, was launched in August 1946, the basic bench lathe retailing at £34.00. The ML7 was so successful that it saw the immediate demise of its predecessor's, the ML2 and ML4.

The Myford "M" type, a Myford's version of the Drummond "M" type. cost £42.00 and production of this discontinued in the early 1950's.

Over it's 33 years production run the ML7 stood the test of time remarkably well. Whilst there were numerous minor changes, the number of major design changes were very few and these are listed below.

In July 1969 at serial number K90494 a cast lug was incorporated into the headstock. The lug is situated just behind the spindle nose and it's initial purpose was to act as an anchor point for the optional lever operated collet attachment. In later years the same point would be used as a pivot point for the chuck guard

In May 1972 from serial number K107657, the existing carriage was converted from the narrow guide to the wide guide principle. On the earlier machines the saddle located across the front two shears and on later models across the full width of the bed, the 5/8" diameter leadscrew and die cast apron were retained.

From lathe No. K108718 the cross slides were fitted with 5mm pitch self locking adjusting screws.

April 1973 saw the introduction of the new bed at serial number K111727, the re-design was necessary to accommodate the power cross feed apron on the Super 7 lathe. At the same time the specification of the ML7 was updated to incorporate the 3/4" diameter leadscrew and cast iron apron as used on the pre-power cross feed Super 7's.

The last machine No. K140848 left the fitting lines on the 31st January 1979.

It should be noted that long bed ML7 lathes were always fitted with a 3/4" diameter leadscrew and the saddle cross slide and top slide as used on the pre-power cross feed Super 7 lathes.

Please Note : When ordering, kindly state the serial number and prefix letter of your lathe. On earlier machines upto serial No. K111727 this will be found on the rear shear of the lathe bed, at the tailstock end of the machine. On later machines after serial number K111727 this will be found on the front of the lathe bed, to the left hand side of the rack.

SERIAL NUMBER.

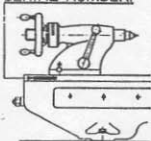

Fig. 2

SERIAL NUMBER

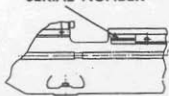

Fig. 2

Popular Spare Parts For ML7 Lathes

Headstock Section:

Part Number	Description	Price Incl VAT	
65174	Sight feed lubricator	£5.06	£ 5.95
11261	Fibre washer	£0.08	£ 0.09
70/1230	Spindle (Original specification) - No longer available		-
70/1205	Spindle bearing (front) white metal - No longer available		-
70/1206	Spindle bearing (rear) white metal - No longer available		-
70/1203	Laminated shim - front bearing	£2.12	£ 2.49
70/1204	Laminated shim - rear bearing	£2.12	£ 2.49
	<p>Note: We are no longer able to purchase further supplies of the original white metal bearings at sensible prices. This has necessitated the supply of the kit detailed below as a direct replacement and in terms of cost is approximately half the price of what a new set of bearings would be.</p>		
	ML7 Headstock spindle and bearing kit:		
A8122	Hardened spindle	£71.62	£ 84.15
A8120	Spindle bearing (front) bronze, complete with shims	£55.20	£ 64.86
A8121	Spindle bearing (rear) bronze, complete with shims	£40.13	£ 47.15
	Price for Headstock spindle with bearings complete	£166.95	£196.16
70/1226	65T Backgear assembly, (including driving key etc...)	£27.10	£ 31.85
70/1227	Backgear key	£3.95	£ 4.64
11163	Special allen key, for above backgear key	£1.43	£ 1.68
70/1218	Backgear cluster assembly 21/56t gear	£13.26	£ 15.58
100405	Socket countersunk screw (2BA x 1/2")	£0.05	£ 0.06
70/1219	Plunger	£4.29	£ 5.04
A4728	Spring	£0.10	£ 0.12
70/1220	Screwed bush	£0.15	£ 0.18
80001	Knob	£0.80	£ 0.94
70/1234/2	Vee cone pulley assembly	£42.90	£ 50.41
70020	Vee belt - Headstock	£5.33	£ 6.26
65390	Oil nipple (replaces 65000)	£0.35	£ 0.41
73044	Thrust bearing	£24.53	£ 28.82
70/1246	25T Gear	£5.11	£ 6.00
11260	Grubscrew (2BA x 3/16") (MY2820)	£0.05	£ 0.06
70/1242	20T Tumbler gear	£8.00	£ 7.05
70/1241	18T Tumbler gear	£5.75	£ 6.76
70/1232/2	Tumbler sleeve gear	£16.10	£ 18.92
70/1249	Soft centre - 2MT	£3.70	£ 4.35
70/1129	6.3/4" Standard Faceplate	£17.50	£ 20.56
70/1137	Catchplate with 11291 drive peg.	£15.30	£ 17.98

Popular Spare Parts For ML7 Lathes

Countershaft and Motorising Section:

Part Number	Description	Price incl VAT	
70/1619/2	Countershaft	£24.08	£28.29
70003	Woodruff	£0.19	£ 0.22
70/1626/6	Vee cone pulley assembly	£20.92	£24.58
A1973	Thrust washer	£0.07	£ 0.08
A1832	Countershaft pulley	£12.29	£14.44
A1227	Hard rubber bush	£3.66	£ 4.30
A2834/1	'Oillite' bush	£1.80	£ 2.11
65390	Oil nipple (replaces 65000)	£0.35	£ 0.41
70/1624	Knob	£3.87	£ 4.55
70/1625	Spring clip	£0.92	£ 1.08
100315	Hexagon head set screw (1/4" B.S.F. x 5/8")	£0.18	£ 0.21
80003	Knob (1.1/4" dia. X 5/16" B.S.W.)	£0.75	£ 0.88
A1851/1	Motor pulley - 5/8" bore	£7.50	£ 8.81
70025	Vee belt - Motor drive	£3.73	£ 4.38

Change Gear Train Section:

70/1138/1	Changewheel stud assembly	£12.71	£14.93
12229	Change gear stud	£7.00	£ 8.23
11928	Change gear bush	£6.05	£ 7.11
11287	Washer	£0.18	£ 0.21
100018	Cheese head screw (2BA x 3/8")	£0.05	£ 0.06
11286	Collar	£3.08	£ 3.60
11278	Grubscrew	£0.05	£ 0.06
70/1132	Spacer	£3.02	£ 3.55
A4736	Change gear quadrant assembly	£9.85	£11.57
70/1131	Thumb screw	£3.22	£ 3.78
70/1909/1	Thumb nut	£2.78	£ 3.27
65390	Oil nipple (replaces 65000)	£0.35	£ 0.41

Rack, Leadscrew and Apron Section :

Part Number	Description	Price incl VAT	
	Note : Diecast Apron spares for lathes with 5/8" diameter Leadscrew prior to K111727. This does not include long bed machines.		
A9179	Rack, with fixing screws - Standard bed	£25.61	£30.09
A9222	Rack, with fixing screws - Long bed	£41.55	£48.82
A4182	Leadscrew - 5/8" Dia. - Imperial - 8 T.P.I. - Standard bed - Changewheel machine	£79.51	£93.42
A4183	Leadscrew - 5/8" Dia. - Imperial - 8 T.P.I. - Standard bed - Quick change gearbox machine	£79.51	£93.42
70/1316	Hand traverse pinion	£10.34	£12.15
70002	Woodruff Key (No.404)	£0.31	£ 0.36
11258	Fibre washer	£0.09	£ 0.10
73074	'Oillite' bush (CT4 x 1.1/4")	£2.20	£ 2.59
70/1331	Handwheel assembly	£23.44	£27.54
70/1315	Rack pinion assembly	£18.19	£21.37
11258	Fibre washer	£0.09	£ 0.10

Popular Spare Parts For ML7 Lathes

Rack, Leadscrew and Apron Section Continued:

73074	'Oilite' bush (CT4 x 1.1/4")	£2.20	£ 2.59
73001	'Oilite' bush (CT15 x 1/4")	£2.10	£ 2.47
11258	Fibre washer	£0.09	£ 0.10
73074	'Oilite' bush (CT4 x 1.1/4")	£2.20	£ 2.59
73001	'Oilite' bush (CT15 x 1/4")	£2.10	£ 2.47
70/1310/1ACC	Leadscrew nut assembly (includes 70/1326 Cam peg, A4729 Spring and 100319 2BA x 1.3/4" Cap head screw)	£11.50	£13.51
11272	Adjusting screw - Gib strip (MY2809)	£0.16	£ 0.18
11271	Adjusting screw - Gib strip (MY2806)	£0.11	£ 0.13
100027	Hex. Locknut (2BA)	£0.06	£ 0.07
A4188/1	Leadscrew guard	£3.75	£ 4.41
80003	Knob - Cam and lever assembly	£0.75	£ 0.88
	Note : Cast Iron Apron spares for lathes with 3/4" diameter Leadscrew after K111727 and onwards. This also includes all long bed lathes.		
A9179	Rack, with fixing screws - Standard bed	£25.61	£30.09
A9222	Rack, with fixing screws - Long bed	£41.55	£48.82
A2054/2	Leadscrew - 3/4" Diameter - Imperial - 8 T.P.I. - Standard bed - Changewheel machine	£46.50	£54.64
A3472	Leadscrew - 3/4" Diameter - Imperial - 8 T.P.I. - Long bed - Changewheel machine	£48.50	£56.99
A3011/1	Leadscrew - 3/4" Diameter - Imperial - 8 T.P.I. - Standard bed - Quick change gearbox machine	£46.50	£54.63
A3839/1	Leadscrew - 3/4" Diameter - Imperial - 8 T.P.I. - Long bed - Quick change gearbox machine	£48.50	£56.99
A2086	Hand traverse pinion	£8.71	£10.23
70002	Woodruff key (No. 404)	£0.31	£ 0.36
11260	Fibre washer (Formerly MY4106)	£0.11	£ 0.13
A2087/1	Handwheel assembly	£23.44	£27.54
A2085	Rack pinion assembly	£16.68	£19.60
11260	Fibre washer (Formerly MY4106)	£0.11	£ 0.13
73001	'Oilite' bush (CT15 x 1/4")	£2.10	£ 2.47
A1975/3ACC	Leadscrew nut assembly (includes 70/1326 Cam peg, A4729 Spring and 100319 2BA x 1.3/4" Cap head screw)	£26.09	£30.66
A9337	Adjusting screw - Gib strip	£0.89	£ 0.99
A9338	Adjusting screw - Gib strip	£1.23	£ 1.44
100027	Hexagon locknut (2BA)	£0.06	£ 0.07

Saddle and Cross Slide Section:

Part Number	Description	Price incl VAT	
	Note : Saddle and Cross Slide - for lathes upto serial number K111727 with Diecast Apron and 5/8" diameter Leadscrew.		
70/1327	Wiper housing	£2.82	£ 3.31
100316	Round head screw (4BA x 3/8")	£0.05	£ 0.06
70/1328	Felt wiper	£1.25	£ 1.47
65390	Oil nipple (replaces 65000)	£0.35	£ 0.41
70/1305	Laminated shim - Front	£2.20	£ 2.59

Popular Spare Parts For ML7 Lathes

Saddle and Cross Slide Section Continued:

Part Number	Description	Price Incl VAT
70/1304	Laminated shim - Rear	£2.20 £ 2.59
70/1311	Saddle adjusting screw - Gib strip	£1.52 £ 1.79
100027	Hexagon locknut (2BA)	£0.06 £ 0.07
11296	Hexagon head bolt - Saddle clamping	£1.23 £ 1.44
100008	Washer (5/16")	£0.03 £ 0.04
70/1312	Clamp eccentric	£2.29 £ 2.69
Note : Saddle and Cross Slide - for lathes after serial number K111727 with Cast Iron Apron and 3/4" diameter Leadscrew.		
11271	Cross slide adjusting screw - Gib strip (MY2806) (For lathes upto serial no. K108718).	£0.11 £ 0.13
100027	Hexagon locknut (2BA)	£0.06 £ 0.07
A8736	Wiper housing	£2.82 £ 3.31
100316	Round head screw (4BA x 3/8")	£0.05 £ 0.06
A8735	Felt wiper	£1.25 £ 1.47
70/1305	Laminated shim - Front	£2.20 £ 2.59
70/1304	Laminated shim - Rear	£2.20 £ 2.59
A7760	Saddle adjusting screw - Gib strip	£0.85 £ 1.00
A7424/1	Saddle adjusting screw - Gib strip	£1.55 £ 1.82
100305	Hexagon locknut (1/4" B.S.F.)	£0.57 £ 0.08
11296	Hexagon head bolt - Saddle clamping	£1.23 £ 1.44
100008	Washer (5/16")	£0.03 £ 0.04
70/1312	Clamp eccentric	£2.29 £ 2.69
A8623	Cross slide adjusting screw - Gib strip - For 70/1308/1 Cross slide	£0.60 £ 0.70
100318	Cross slide adjusting screw - Gib strip - For 70/1308/1 Cross slide	£0.20 £ 0.23
70/1308/1	Cross slide - Standard - No longer available - Use A1513/1	-
A1513/1	Cross slide - Long (This Cross slide is 1.7/16" longer than the standard Cross slide giving an additional tee slot)	£53.19 £62.50
70/1301	Cross slide end plate	£6.78 £ 7.97
70/1321	Feedscrew - Imperial - 10 T.P.I. - Standard cross slide	£6.41 £ 7.53
30/133	Feedscrew - Imperial - as above but - Fitted feednut - Std. cross slide	£10.79 £12.68
A3239	Feedscrew - Imperial - 10 T.P.I. - Long cross Slide	£9.66 £11.35
30/135	Feedscrew - Imperial - as above but - Fitted feednut - Long cross slide	£13.87 £16.30
70/1302	Feednut - Imperial - 10 T.P.I.	£4.95 £ 5.81
A4730	Feedscrew - Metric - 2mm Pitch - Standard cross slide	£6.41 £ 7.53
30/134	Feedscrew - Metric - as above but - Fitted feednut - Std cross slide	£10.79 £12.68
A7822	Feedscrew - Metric - 2mm Pitch - Long cross Slide	£9.66 £11.35
30/136	Feedscrew - Metric - as above but - Fitted feednut - Long cross slide	£13.87 £16.30
A1648	Feednut - Metric - 2mm Pitch	£4.95 £ 5.81
70/1984A	Hard washer	£0.12 £ 0.14
11257	Fibre washer	£0.08 £ 0.09
11107	Steel micrometer dial (replaces 70/1303 Mazak dial)	£7.00 £8.23
or		
20/252	Re-settable micrometer dial	£10.65 £12.51
A1382/3	Gib strip	£4.00 £ 4.70
70/1337	Ball handle assembly	£10.10 £11.87
A8623	Cross slide adjusting screw - Gib strip	£0.60 £ 0.70
100318	Cross slide locking screw	£0.25 £ 0.29
Note : For long bed ML7 lathes, refer to Super 7 spares list pages 5 and 6.		

Popular Spare Parts For ML7 Lathes

Top Slide Section :

Part Number	Description	Price incl VAT	
11292	Top slide assembly complete - Imperial	£131.78	£154.84
13726	Top slide assembly complete - Metric	£131.78	£154.84
70/1403	Top slide	£20.42	£ 23.99
70/1401	End plate	£5.30	£ 6.22
70/1408	Feedscrew - Imperial - 10 T.P.I.	£6.70	£ 7.87
30/137	Feedscrew - Imperial - as above but - Fitted feednut	£11.06	£ 12.30
70/1302	Feednut - Imperial - 10 T.P.I.	£4.95	£ 5.81
A4731	Feedscrew - Metric - 2mm Pitch	£6.70	£ 7.87
30/138	Feedscrew - Metric - 2mm Pitch - as above but - Fitted feednut	£11.06	£ 12.30
A1648	Feednut - Metric - 2mm Pitch	£4.95	£ 5.81
70/1984A	Hard washer	£0.12	£ 0.14
11257	Fibre washer	£0.08	£ 0.09
11107	Steel micrometer dial (replaces 70/1303 Mazak dial)	£7.00	£ 8.23
	or		
20/252	Re-settable micrometer dial	£10.65	£ 12.51
11293	Ball handle assembly	£8.12	£ 9.54
11269	Adjusting screw - Gib strip	£0.25	£ 0.29
100027	Hexagon locknut (2BA)	£0.06	£ 0.07
70/1406	Tool clamp stud	£5.42	£ 6.37
A2806	Spring	£0.27	£ 0.32
70/1409/1	Tool clamp	£4.61	£ 5.42
70/1413	Adjusting screw assembly	£4.03	£ 4.74
70/1410	Spherical washer	£1.25	£ 1.47
70/1412	Tool clamp locking nut	£0.62	£ 0.73
A1845	Tee nut, complete with A7742 hex headed bolt and washer (Two required per machine)	£2.96	£ 3.48
	Note : For long bed ML7 lathes, refer to Super 7 spares list pages 7 and 8.		

Tailstock Section :

13356	Tailstock assembly complete	£216.75	£254.68
A2798	Barrel	£29.61	£ 34.79
70/1506	Barrel key	£2.06	£ 2.42
70/1520/1	Handwheel assembly	£36.23	£ 42.57
70/1509	Thrust plate	£7.89	£ 9.27
70/1248	Hard centre - 2 M.T.	£5.35	£ 6.28
A2137	Thrust screw - Gib strip	£5.31	£ 6.24
A2146	Set over screw	£0.59	£ 0.69
65390	Oil nipple (replaces 65000)	£0.35	£ 0.41

Popular Spare Parts For ML7 Lathes

Plates :

A2639	Screw cutting chart	£2.05	£ 2.41
	Transfer for headstock belt guard	£0.42	£ 0.50

Sundries :

Part Number	Description	Price incl VAT	
33/038	Paint - Grey - 250ml tin (Air drying enamel)	£4.20	£ 4.94
80163	Castrol Moly grease - 400gm. tub - ideal for changewheels, feedscrew and leadscrews.	£3.02	£ 3.55
80024	Lubricating oil - H32 Nuto - 1 Ltr. For headstock spindle, tailstock barrel and oilite bushes.	£3.80	£ 4.47
80025	Lubricating oil - Febis K68 - 1 Ltr. For bed, slideways and gearbox.	£3.80	£ 4.47
	Installation and maintenance manuals (Nil V.A.T. on manuals)		
82005	ML7	£4.45	-
82006	Quick change gearbox	£1.70	-

Extra Equipment :

Part Number	Description	Price incl VAT	
1480	Quick change gearbox	£531.50	£624.51
1440A	Lever operated tailstock attachment £78.50		£ 92.24
30/021A	Chuck guard for machines before lathe Serial No. K.91000	£60.40	£ 70.97
30/021	Chuck guard for machines after lathe Serial No. K.91000	£37.32	£ 48.85
30/027	Chuck guard Kit to meet requirements of health and Safety at work etc. Act, 1974, comprising: primary drive guard backplate, guard for rear end of headstock spindle and guard for swing head, including No. 30/021 chuck guard (please state serial number of machine) for machines after lathe Serial No. K.91000	£84.64	£ 99.45
A1781	18T Tufnol pinion for tumbler reverse	£5.75	£ 6.75
A1782	20T Tufnol pinion for tumbler reverse	£5.95	£ 6.99
A1974/1	Fine feed tumbler cluster gear	£12.50	£ 14.68
11574	Lathe cover	£14.60	£ 17.15
11575	Lathe cover for long bed lathe	£16.00	£ 18.80

Copyright (C) 1997 Myford Ltd.

Published by Myford Ltd. Printed in Great Britain

All rights reserved. No part of this publication may be reproduced, stored in a retrieval system, or transmitted in any form or by any means, electronic, mechanical, photocopying, recording or otherwise, without the prior written permission of the publishers.
Illustrations not binding in detail. Design and specification subject to change without notice.

Myford Limited,
Wilmot Lane, Chilwell Road,
Beeston, Nottingham,
England, NG9 1ER.

Tel: (0115) 9254222. Fax: (0115) 9431299