

READ INSTRUCTIONS CAREFULLY

BEFORE USING MACHINE

When this instruction book was printed the information given was up-to-date. However, Hardinge is constantly improving the design of their machine tools and it is possible that the illustrations and descriptions may vary somewhat from the machine you received. This merely implies that the machine you received is the latest improved model to better fulfill your requirements.

HARDINGE BROTHERS, INC.

ELMIRA, NEW YORK

© 1954

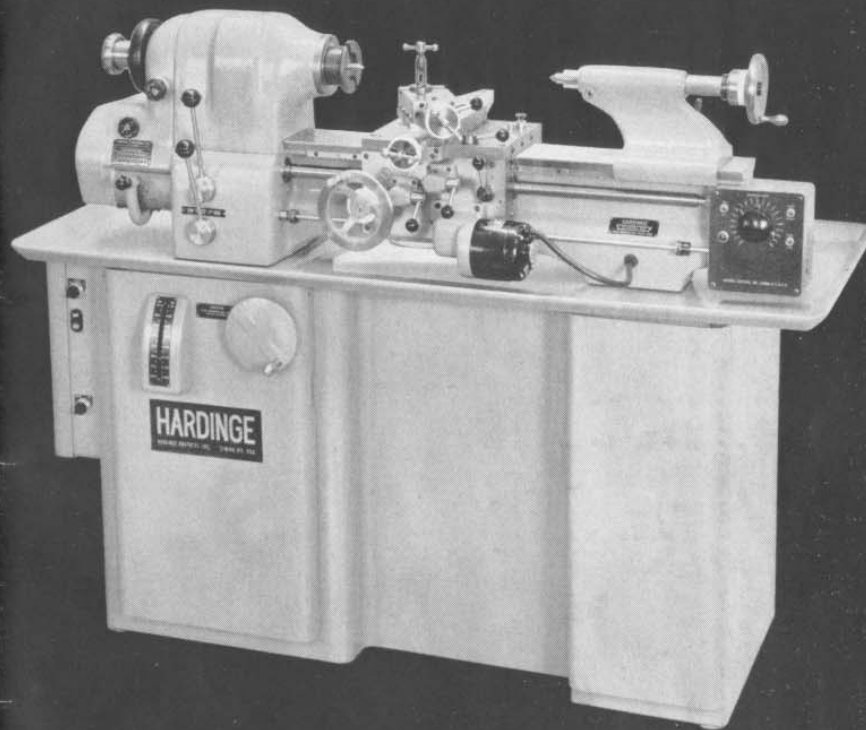

MODEL HLV

HARDINGE HIGH SPEED TOOL ROOM LATHE

with

HARDINGE

DOVETAIL BED

SOLID HARDENED AND GROUND STEEL

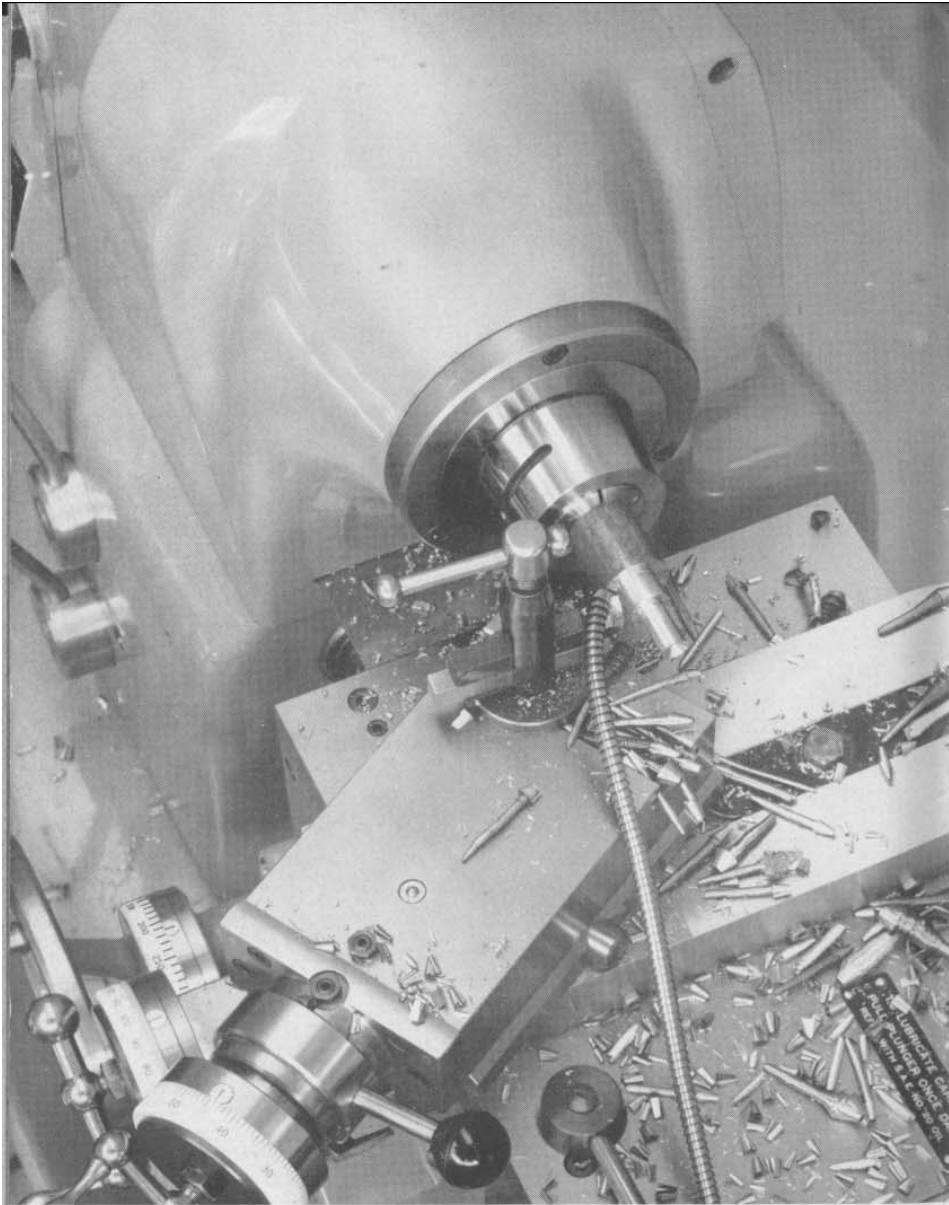

An example of modern turning with work held in a collet. With the Hardinge HLV Lathe the collets seat directly in the spindle for maximum accuracy and rigidity. For fast, accurate, easy chucking, use collets to hold your work — available in round, hexagon and square fractional sizes from collet stocks in Elmira, New York, and twelve principal cities.

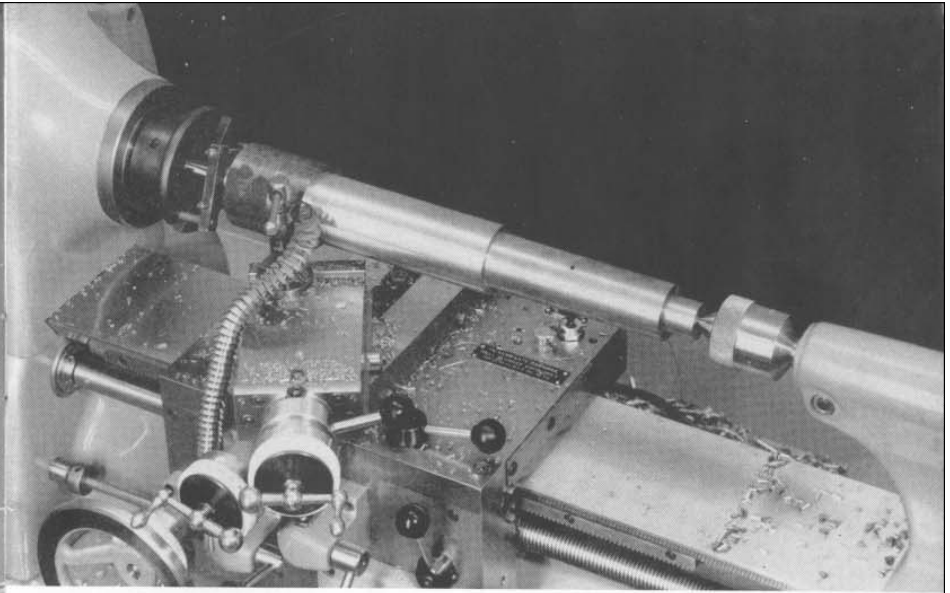

The setup illustrated above is given to show the range of the Hardinge HLV Lathe. Compare it to the illustration at the top of Page 4.



Precision taper turning is easy when done on the Hardinge HLV Lathe equipped with a taper turning attachment.

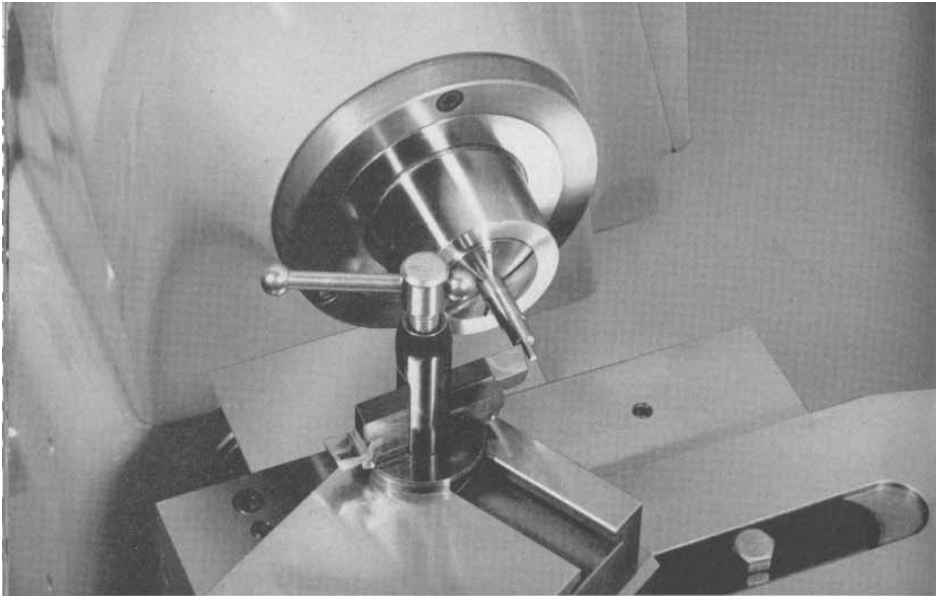

The smooth, powerful endless V-belt drive of the Hardinge HLV Lathe, coupled with the high speeds obtained, make small diameter work easy and efficient.

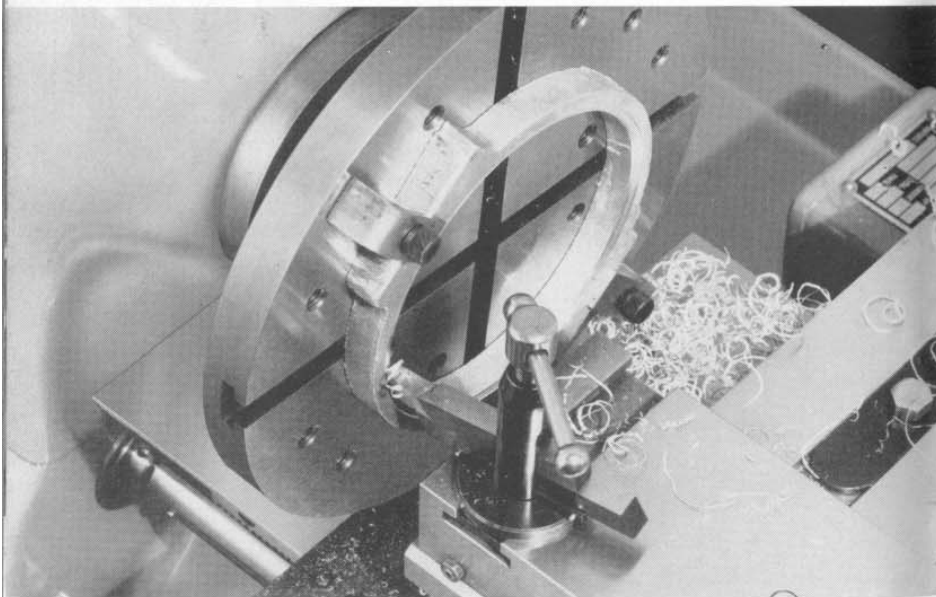

This large diameter job uses the large tapped and slotted face plate — one of the many items of spindle nose tooling available to increase versatility of the Hardinge HLV Lathe.

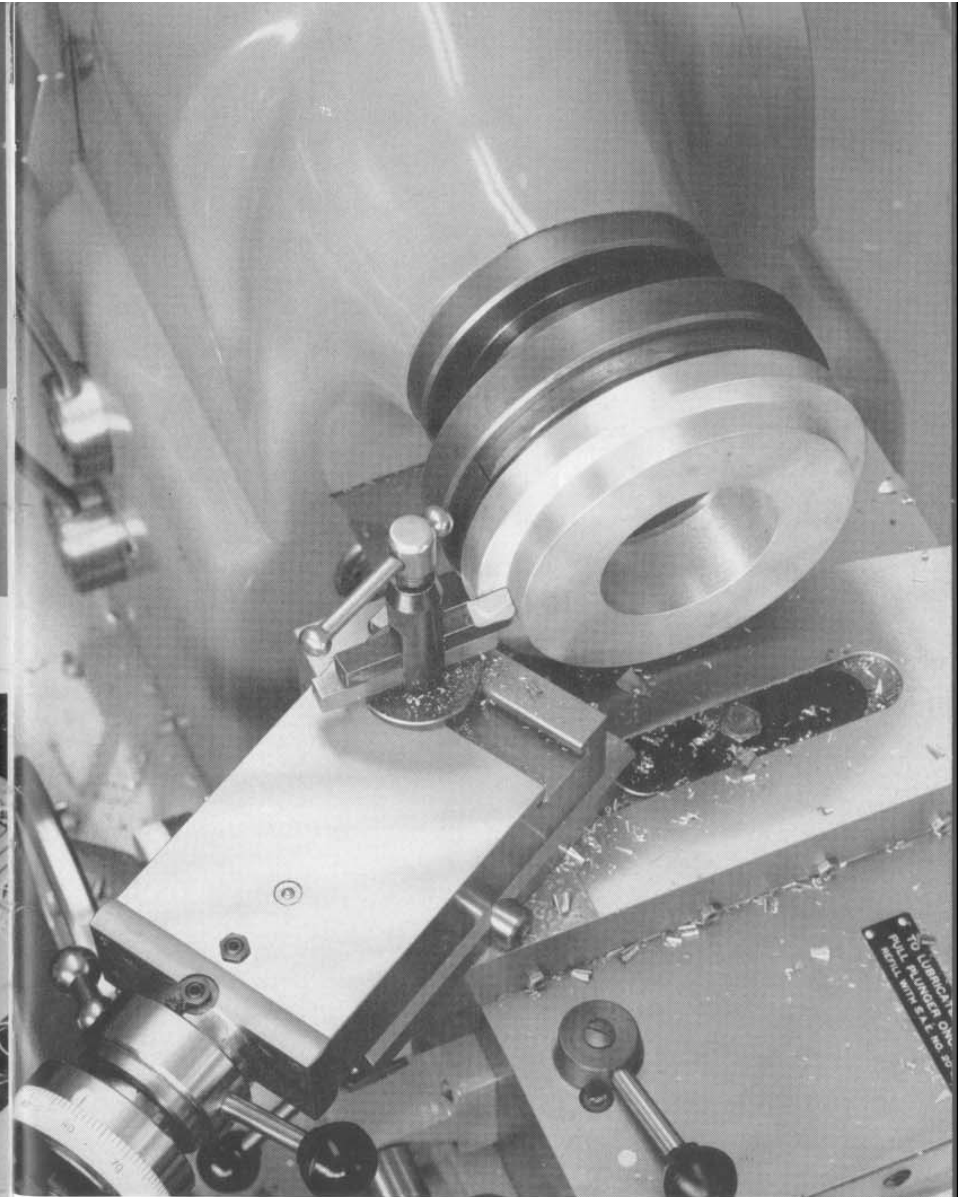

An example of proper holding of an instrument part for accurate, high speed machining by holding the part in a standard step chuck. See Pages 50, 51, 52 and 53 for full information on step chucks and closers.

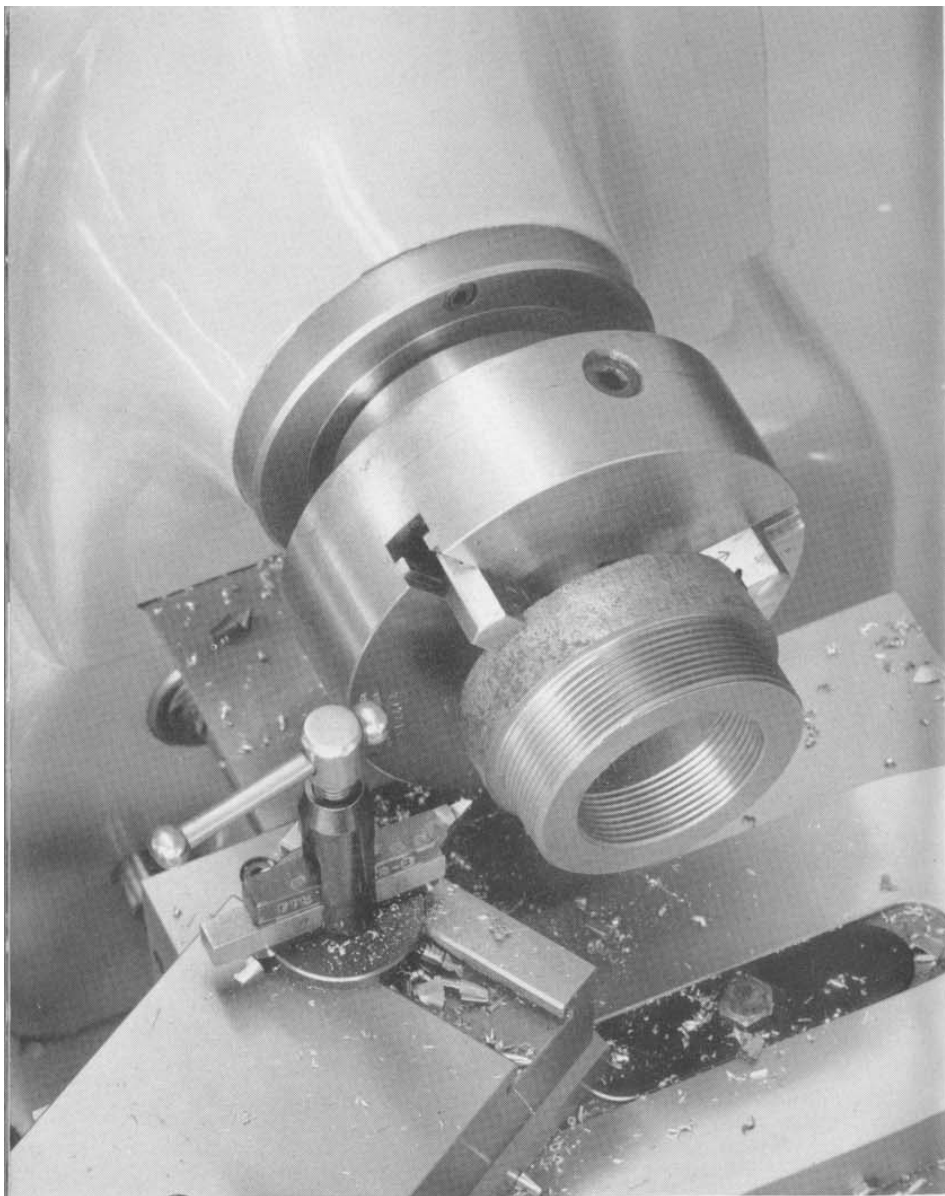

The setup illustrated above shows the use of a three jaw chuck to hold a forged steel part. Four jaw chucks are also available—see Page 48.

INSTALLATION INSTRUCTIONS

Remove crating, but do not remove machine from skid. Move machine to the location in your plant where it is to be used and then remove machine from skid. See instructions below for lifting machine from skid.

LIFTING MACHINE. Remove the three bolts which hold the machine to the shipping skids. There are two bolts at the extreme left-hand end of the pedestal and one at right-hand end.

The machine may be removed from the skid by either a crane or fork lift truck. Lifting with a crane, the rope or cable sling should be arranged as shown on this page. **NEVER LIFT MACHINE WITH ROPE OR CABLE AROUND SPINDLE, BED OR TAILSTOCK.**

The rope or cable must be capable of withstanding a weight of 2000 pounds. When using a lift truck, adjust forks to go in between top planks of skid and bottom of pedestal base. Lift machine slowly, checking to see that the correct balance is obtained. Use caution, as machine has somewhat more weight at the front and it is more easily tipped using the lift truck method than the crane and sling method.

After skid has been removed place machine directly on location where it is to be used.

MACHINE FOUNDATION. The Hardinge HLV Precision Lathe is designed to operate without the need of special foundations. A substantial wood or concrete floor is satisfactory. It must, however, be fairly flat and have sufficient strength to support machine properly.

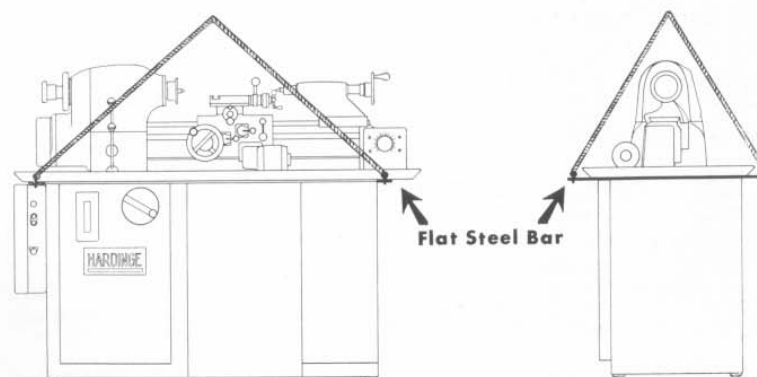

Do not locate machine near other equipment that causes vibration

INSTALLATION INSTRUCTIONS (Continued)

which will transmit to this machine, as poor work finish will result.

LEVELING MACHINE. The Hardinge HLV Precision Lathe is designed with a three point bearing arrangement between bed and pedestal base. The three point bearing arrangement makes accurate leveling unnecessary. Leveling should be such as to be reasonable and so that when coolant is used it will drain back into sump from ends of pan.

There is an adjustable foot at back right-hand corner of the pedestal base to compensate for uneven floor conditions. To adjust, loosen the socket set screw and raise or lower the foot with a pin wrench so that all four feet rest firmly on the floor. Tighten socket set screw to retain setting. Should floor conditions be such that adjustable foot does not take care of the leveling, use shims under feet of pedestal.

CLEANING MACHINE. Use a cloth or brush to clean this precision machine. **DO NOT CLEAN MACHINE WITH COMPRESSED AIR.** The use of compressed air for cleaning a machine reduces the precision life of the machine. Small particles of dirt and foreign matter can be forced past seals and wipers into the precision slides and bearings. **USE ONLY CLOTH OR BRUSH TO CLEAN MACHINE.** This also applies to daily cleaning of unit after it is in operation.

After machine has been properly located, leveled and bolted to floor, wash off all slushing grease or oil and dirt accumulated in transit with naphtha or other good solvent of grease. Clean motor compartment. Be sure to remove all grease from pulleys — wipe pulleys dry. Rotate pulleys by hand and check to see that all grease is removed. Apply a small amount of oil to brake drum as described on Pages 14 and 15.

ELECTRICAL CONNECTIONS. Before proceeding read instructions "To Start and Stop Spindle" on Page 11. The machine is shipped completely wired and assembled. It is only necessary to run the electric power line to the bottom of the control panel and attach the wires to the terminal block in the panel. **BEFORE CHECKING ROTATION APPLY A COLLET TO THE MACHINE SPINDLE TO ANCHOR THE COLLET CLOSER OR DRAW SPINDLE IN PLACE, OR REMOVE THE COLLET CLOSER OR DRAW SPINDLE FROM THE HEADSTOCK SPINDLE.** See Page 17 for instructions on "How To Remove Collet Closer." Attach the power line to the terminal block in the control panel and check spindle rotation. Spindle should run in the forward direction when control lever "A", Figure 1, Page 11, is in either the left or right-hand position and forward-reverse selector switch at front of control panel is in Forward position.

BE SURE SPINDLE LOCK PIN "D", Figure 1, Page 11, **AT REAR OF HEADSTOCK IS IN THE "OUT" OR RELEASED POSITION BEFORE STARTING.** Electric power feed for carriage is connected to main control panel and does not require a separate power line.

MACHINE SPECIFICATIONS

Spindle Construction	Hardinge Preloaded Ball Bearing
SPINDLE CAPACITY	With Step Chucks 1" to 6"
	With Jaw Chucks 5"
	With Jaw Chucks (Through Spindle) 1-5/32"
	With Round 5C HARDINGE Collets 1"
	With Hexagon 5C HARDINGE Collets 7/8"
	3/4"
Spindle Nose	Hardinge Tapered
Variable Spindle Speeds	125 to 3000 r.p.m.
Swing Over Bed	11"
Swing Over Carriage	9"
Swing Over Cross Slide	5-3/4"
Distance Between Centers:	
Tailstock Flush	18"
Tailstock Overhung	20"
Range of Threads in Gear Box	11 to 108
Number of Thread Changes in Gear Box	27
Actual threads cut through gear box —	11, 11½, 12, 13, 14, 16, 18, 20, 22, 23, 24, 26, 27, 28, 32, 36, 40, 44, 46, 48, 52, 54, 56, 64, 72, 80, 108
NOTE: Standard threads in all standard English systems are included in the foregoing gear box selections.	
Compound Slide Travel	3"
Power Feed Range	1/4 to 7" per minute
Size of Lathe Tool	3/8" by 1"
Tailstock Spindle Travel	3-3/4"
Tailstock Spindle Taper	No. 2 Morse
Approximate weight of machine with regular equipment listed below 1250 lbs.	

REGULAR EQUIPMENT

The Hardinge HLV Lathe is furnished complete with:

- Fully enclosed headstock with preloaded ball bearing 1" collet capacity spindle.
- Drive Plate and Headstock Center.
- Lever Collet Closer or Draw Spindle and Spanner Wrench.
- Quick Change Gear Box reserved for precision cutting of 27 different threads.
- Set of five change gears.
- Completely Enclosed Carriage and Apron.
- Independent Electrical Variable Power Feed Drive for carriage and cross slide.
- Finger Tip Snap-Up Clutches for longitudinal and cross feed.
- Preloaded Ball Bearing Lead Screw for threading only.
- Automatic Lead Screw Stop with adjustable stop collars.
- Quick-acting Tool Post Slide for threading.
- Easy Reading Black and White Feed Screw Dials.
- Easy Reading Black and White Carriage Handwheel Dial.
- Solid Full Bearing Carriage.
- Solid Hardened and Ground Steel Dovetail Bed Ways.
- Constant Full Bearing Tailstock with No. 2 Morse Taper.
- Welded Steel Base with oil type chip pan and coolant sump.
- Tool Storage Compartment with Collet Board.
- Variable Speed Driving Unit complete with 2-speed motor.
- Magnetic Electric Control Panel with transformer providing 110 volts for push button control circuit; time lag thermal overload relays provide overload protection; low voltage protection is also provided; forward and reverse selector switch; cam operated, quick make and quick break switches.

Completely wired and assembled when delivered.

Additional tooling items are shown on Pages 46 thru 68

OPERATING INSTRUCTIONS

FOR

HARDINGE MODEL HLV LATHE

SPINDLE CONTROL LEVER — Figure 1

LOW-STOP-HIGH SPINDLE CONTROL LEVER "A" is connected to a two-speed electric controller located in the electric control panel. Directly behind the lever is a plate indicating three positions **LOW-STOP-HIGH**. By moving the lever to the left, the brake is released and the motor and spindle will run at the selected **"LOW"** speed. Moving the lever to the extreme right also releases the brake and the selected **"HIGH"** speed is obtained. The lever may be moved directly from **LOW** to **HIGH** or from **HIGH** to **LOW** at any time. When this lever is in the center or **"STOP"** position, the motor is shut off and the brake is applied.

THREADING CONTROL LEVER FOR CARRIAGE — Figure 1.

Lever **"B"** controls the direction of carriage movement when threading. Place this lever in the center position as shown before starting machine. See Page 38 for detailed description covering operation of lever **"B"**.

GEAR BOX DISCONNECT KNOB — Figure 1.

Knob **"C"** is used to connect or disconnect the gear box from the headstock spindle by means of a sliding gear. Turn this knob to the extreme left to disconnect the gear box. Knob should always be in the **"Feed"** position before starting machine except when threading — See Page 30 for positioning for threading.

SPINDLE LOCK PIN — Figure 1.

The spindle lock pin **"D"** is located near the top and at the back side of the headstock. The pin is held in the **"OUT"** or released position by a spring and ball plunger.

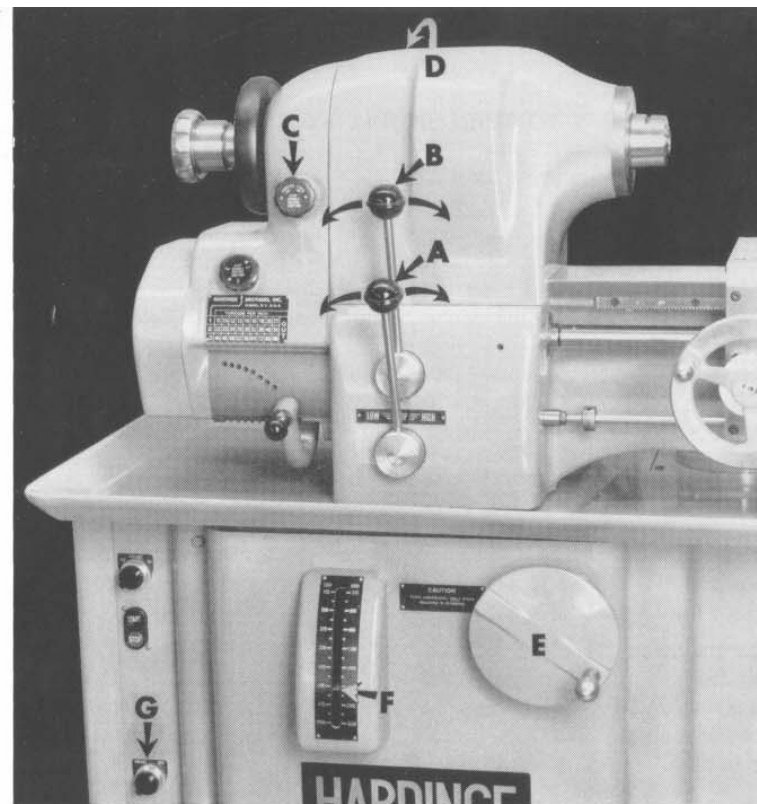

Figure 1

The spindle lock pin is used to hold the headstock spindle stationary when applying or removing spindle nose attachments, adjusting collet closer, tightening draw spindle or when applying and removing work from fixtures or threaded arbor. To engage lock pin, turn spindle by hand and hold lock pin **"in"** until it engages in one of the notches of the spindle assembly. **BE SURE TO WITHDRAW LOCK PIN BEFORE STARTING MACHINE.**

TO START AND STOP SPINDLE — Figure 1.

Pull out spindle lock Pin **"D"**. Press **"START"** button in front of electric control panel at left-hand end of pedestal base. Place lever **"A"** in either the **"LOW"** or **"HIGH"** position to start spindle. To **"STOP"** spindle, place lever **"A"** in the center position, as shown. Use lever **"A"** for all starting and stopping of spindle. Press the **"STOP"** button in the front of the electric control panel when finished using lathe, or at the end of the work day. Pressing the **"STOP"** button disconnects the entire electric control panel from the magnetic starter.

TO TURN SPINDLE BY HAND

When mounting spindle nose tooling or engaging the gear box it is sometimes desirable to rotate the headstock spindle by hand. Also, when setting up or chucking work which requires the work to be indicated for concentricity, the spindle should be turned by hand. To obtain a free spindle for easy turning of the spindle by hand, place lever "A", Figure 1, in the center or stop position. Turn selector switch "G" at the front of the electric control panel to the "OFF" position. Placing the selector switch in the "OFF" position energizes the brake solenoid releasing the spindle drive brake. Electric control panel must be "ON" for solenoid to work.

LUBRICATION OF HEADSTOCK SPINDLE BEARINGS

The headstock spindle is mounted on precision preloaded ball bearings. The preloading and resulting load carrying capacity is engineered to take radial thrust or end thrust, or a combination of both.

The precision preloaded ball bearings are grease-packed for life and require no further lubrication. The entire bearing assembly is housed as a unit and is properly sealed to exclude dirt and foreign matter. The spindle bearing seals are designed to operate at speed without wear or friction.

VARIABLE SPEED DRIVE FOR SPINDLE — Figure 1.

The variable speed drive permits the operator to select the spindle speed best suited for the work. To change the spindle speed place **LOW-HIGH** lever "A" in either the "LOW" or "HIGH" speed range position. This will start the motor and spindle. Turn variable speed control handwheel "E" to obtain speed desired.

CAUTION: DO NOT TURN HANDWHEEL UNLESS THE MACHINE IS RUNNING.

Speed obtained is shown on spindle speed plate by pointer "F", Figure 1. The low speed range of 125 to 1000 r.p.m. is obtained from the variable speed drive when **LOW-HIGH** lever "A" is in the extreme left or "LOW" speed range position. The high speed range of 375 to 3000 r.p.m. is obtained when lever "A" is in the extreme right or "HIGH" speed range position.

If the work requires the use of both the high range and low range, lever "A" can be moved directly from either position to the other without stopping the spindle. The variable speed control handwheel "E" can be turned to the spindle speed desired while the tool is cutting, thus permitting the operator to obtain the required surface finish and production rate.

To open the door to the motor compartment it is necessary to remove the variable speed control handwheel. Use a 5/32" hexagon socket set screw wrench to loosen set screw in handwheel hub — see Figure 2. When replacing handwheel be sure cone point of set screw seats in cone dimple in shaft.

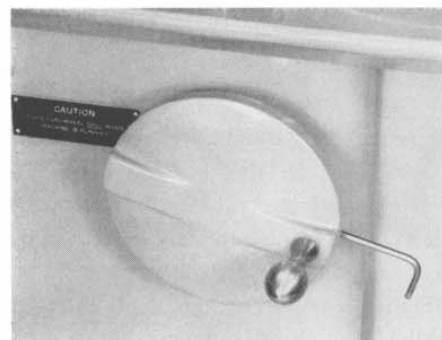

Figure 2

The variable speed drive consists of a powerful two-speed electric motor connected to the spindle by two endless V-belts. One V-belt, "A", Figure 3, runs from the motor to the variable speed driveshaft. The second V-belt runs from the driveshaft to the headstock. When it is necessary to replace a drive belt it is recommended that both belts be replaced for best performance. Belts should be purchased in matched sets from Hardinge Brothers, Inc.

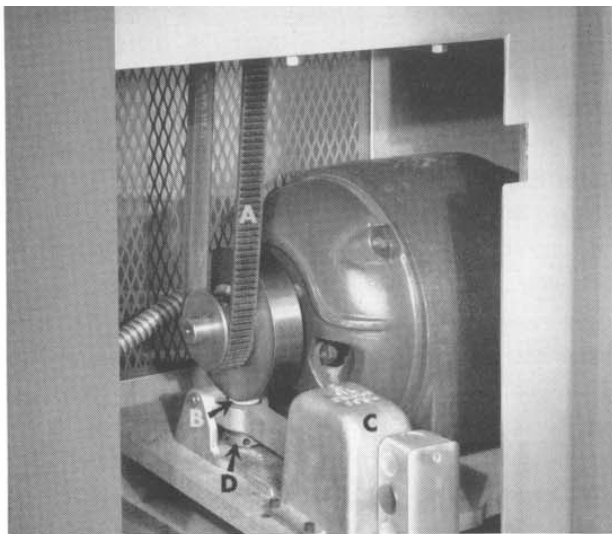

Figure 3

SPINDLE DRIVESHAFT BRAKE — Figure 3.

Spindle brake is designed for rapid but gradual stopping of the precision headstock spindle at all speeds. The **LOW-STOP-HIGH** Lever "A", Figure 1, controls the brake. The brake is moved away from the brake drum by a solenoid located directly in front of the motor pulley. The solenoid is accessible by removing cover "C", Figure 3. The brake cork "B", Figure 3, is forced against the brake drum by means of a powerful spring. The spring automatically compensates for cork wear. However, after considerable use it may be necessary to adjust the brake. This is easily done by placing the **LOW-STOP-HIGH** Lever "A", Figure 1, in the "STOP" position. Then, turn selector switch "G", Figure 1, to the "OFF" position, thus releasing the brake cork from the brake drum. With the brake in the released position turn threaded plunger "D" with 1/4" pin wrench until the cork touches the brake drum. Then back off one half turn until curve in top of cork is in a position to mate with curve of brake drum.

CAUTION: BE SURE BRAKE CORK DOES NOT TOUCH BRAKE DRUM WHEN IN RELEASED POSITION.

After making proper adjustment, as described before, apply a few drops of spindle oil to brake drum. The oil will not materially affect stopping time and will give added life to brake cork. **DO NOT RUN BRAKE CORK DRY.**



Figure 4

TO ADJUST BELT TENSION

After considerable use it may be necessary to adjust the tension on the drive belts. This is accomplished by backing off hexagon lock nut "A", Figure 4. Turn adjusting screw "B" counter-clockwise to lower motor plate and increase tension on drive belts. Increasing the tension on the motor belt automatically increases the tension on the belt connecting the driveshaft to the headstock spindle. Make adjustment in small amounts—run machine to permit belts to equalize. Then check for tension and lock check nut "A" to retain final setting.

Tension on belts should not be excessive, belts should deflect to finger pressure approximately 1" when properly adjusted. Excessive tension causes rapid belt wear and possibly introduces vibration.

DRIVE SHAFT BEARINGS are precision ball bearing type, grease packed and sealed, requiring no further attention.

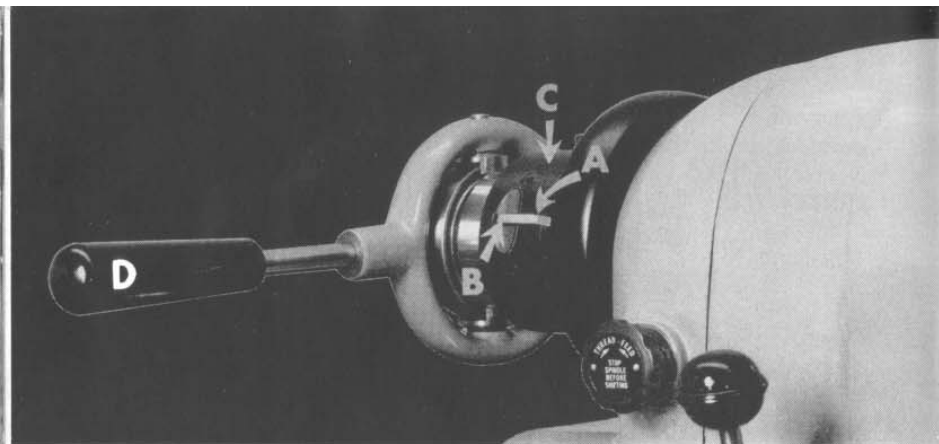

Figure 5

ADJUSTING COLLET CLOSER — Figure 5.

1. Apply the desired size collet or step chuck to the machine spindle. Be sure the collet or step chuck and spindle are clean.
2. Open collet closer latch "A" by pressing down at point "B".
3. Start the collet closer tube on the collet or step chuck and thread about two turns only. To turn the collet closer tube, the operator, using his left hand, turns the black shell guard "C" forward while he holds the collet or step chuck in place with his right hand.
4. Place a work piece in the collet or step chuck.
5. Move lever "D" to the extreme left or closed position and then turn shell guard "C" toward the operator until it is drawn up as far as it will go by hand. If headstock spindle should turn, lock spindle by pressing in spindle lock pin.
6. Move lever "D" to the right to the released position and turn shell guard "C" toward operator so that latch "A" advances two notches on the adjusting nut "H" — Figure 7.
7. Close latch "A" and test collet closer for tension on work. Should additional gripping pressure on the work be required, open latch "A" and turn shell guard "C" toward operator. For less gripping pressure, turn shell guard "C" away from operator.

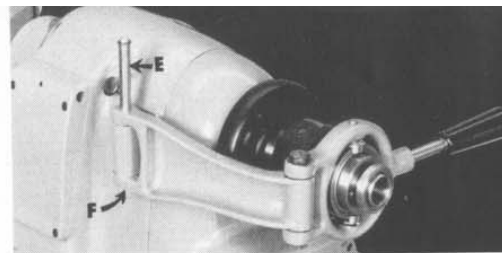

Figure 6

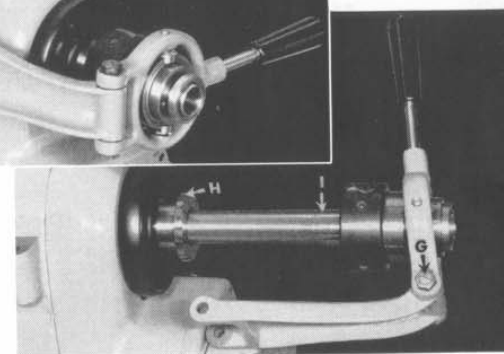

Figure 7

HOW TO REMOVE COLLET CLOSER — Figures 6 and 7.

The collet closer should be removed from the machine when using jaw chucks, face plates, fixture plates or other nose type fixtures. Running the machine with the collet closer in place and **without a collet** will cause damage to the collet closer. It is also a good practice to remove the collet closer assembly occasionally and clean the inside of the headstock spindle. This is easily done by the use of a cloth and length of small diameter bar stock.

To remove the collet closer remove link pin "E". This pin is easily removed by the use of a mallet and brass punch, striking pin at the bottom point "F".

CAUTION: DO NOT REMOVE COLLET CLOSER BY REMOVING SCREW "G". This screw is adjusted properly at the factory for proper operation of collet closer. Remove link pin "E", Figure 6, only. After removing pin "E" remove collet closer as shown. It is then necessary to remove adjusting nut "H". This is done by pulling nut straight off end of spindle. **DO NOT TURN ADJUSTING NUT — IT IS NOT THREADED TO SPINDLE.**

APPLYING COLLET CLOSER — Figures 6 and 7

Clean the inside of the headstock spindle before applying collet closer. Also, clean outside diameter at rear of spindle where adjusting nut locates. Clean collet closer tube inside and out.

Apply a film of light oil on outside rear of headstock spindle and apply adjusting nut "H". Apply a film of light oil on bearing, section "T", of collet closer tube and slide closer on machine and insert link pin "E".

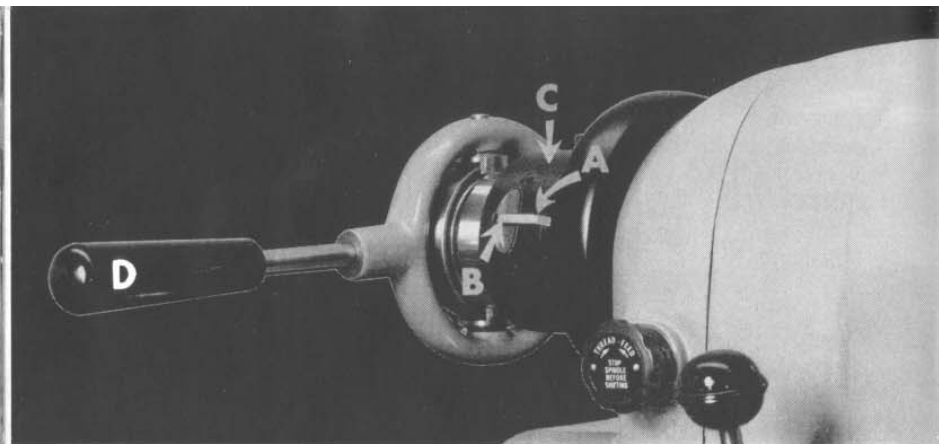

Figure 5

ADJUSTING COLLET CLOSER — Figure 5.

1. Apply the desired size collet or step chuck to the machine spindle. Be sure the collet or step chuck and spindle are clean.
2. Open collet closer latch "A" by pressing down at point "B".
3. Start the collet closer tube on the collet or step chuck and thread about two turns only. To turn the collet closer tube, the operator, using his left hand, turns the black shell guard "C" forward while he holds the collet or step chuck in place with his right hand.
4. Place a work piece in the collet or step chuck.
5. Move lever "D" to the extreme left or closed position and then turn shell guard "C" toward the operator until it is drawn up as far as it will go by hand. If headstock spindle should turn, lock spindle by pressing in spindle lock pin.
6. Move lever "D" to the right to the released position and turn shell guard "C" toward operator so that latch "A" advances two notches on the adjusting nut "H" — Figure 7.
7. Close latch "A" and test collet closer for tension on work. Should additional gripping pressure on the work be required, open latch "A" and turn shell guard "C" toward operator. For less gripping pressure, turn shell guard "C" away from operator.

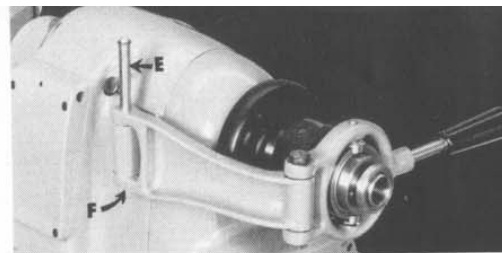

Figure 6

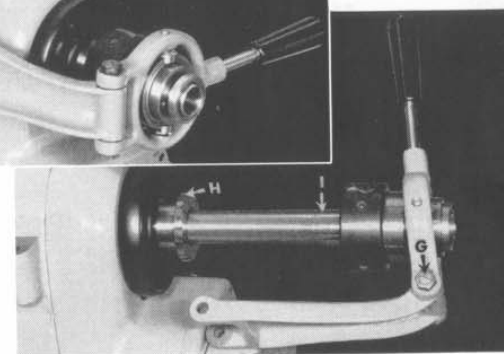

Figure 7

HOW TO REMOVE COLLET CLOSER — Figures 6 and 7.

The collet closer should be removed from the machine when using jaw chucks, face plates, fixture plates or other nose type fixtures. Running the machine with the collet closer in place and **without a collet** will cause damage to the collet closer. It is also a good practice to remove the collet closer assembly occasionally and clean the inside of the headstock spindle. This is easily done by the use of a cloth and length of small diameter bar stock.

To remove the collet closer remove link pin "E". This pin is easily removed by the use of a mallet and brass punch, striking pin at the bottom point "F".

CAUTION: DO NOT REMOVE COLLET CLOSER BY REMOVING SCREW "G". This screw is adjusted properly at the factory for proper operation of collet closer. Remove link pin "E", Figure 6, only. After removing pin "E" remove collet closer as shown. It is then necessary to remove adjusting nut "H". This is done by pulling nut straight off end of spindle. **DO NOT TURN ADJUSTING NUT — IT IS NOT THREADED TO SPINDLE.**

APPLYING COLLET CLOSER — Figures 6 and 7

Clean the inside of the headstock spindle before applying collet closer. Also, clean outside diameter at rear of spindle where adjusting nut locates. Clean collet closer tube inside and out.

Apply a film of light oil on outside rear of headstock spindle and apply adjusting nut "H". Apply a film of light oil on bearing, section "T", of collet closer tube and slide closer on machine and insert link pin "E".

HOW TO CHANGE BELTS

The spindle of the Hardinge HLV Lathe is driven from the motor by two special matched endless V-belts. After considerable use, it may be necessary to apply new belts to the machine.

IMPORTANT: The headstock for machines with serial numbers in the Group 124 to 399 must be returned to the factory in Elmira, New York, for belt replacement as these units do not have a quill-type spindle to permit the changing of belts by users. **DO NOT ATTEMPT TO REMOVE THE HEADSTOCK SPINDLE ON THESE MACHINES.**

The following instructions and drawings on opposite page make changing of belts easy on machines having a serial number of HLV-400 or above:

TO REMOVE SPINDLE, SPINDLE BELT AND MOTOR BELT

1. With machine running, reduce spindle speed to 125 R.P.M. the lowest speed setting for variable speed indicator. Then stop machine.
2. Loosen set screw "A" and remove handwheel "B" to open door.
3. Remove nut "C" using a suitable pry bar to raise motor plate approximately 2" or enough to slip motor belt from motor pulley.
4. Loosen screw "D" and pull out pulley shaft "E".
5. Remove pulley assembly "F". This is done by first raising the pulley unit enough to remove spindle drive belt from pulley unit; then lowering pulley unit through the opening in the drive frame.
The motor belt can also be removed at this time.
6. Remove lever collet closer or draw bar from headstock spindle.
7. Remove cover from rear of head and pull spindle drive belt up through opening at rear of headstock.
8. Remove snap ring "G" with screw driver and pull handwheel "H" off end of spindle. Remove Woodruff key, wave washer and spacer "I".
9. Remove lock screw, taper set screw, and set screws "J" through opening in rear of head.
10. Place knob "K" to "Thread" position.
11. Remove the three socket head screws "L" from front cap.
12. Slide pulley "M" as far toward the rear of the spindle as possible. If pulley cannot be moved by hand, place wood block between pulley and front bearing boss as shown.
13. Tap on rear end of spindle with rawhide mallet while pulling the spindle assembly out from the front of the headstock frame. The spindle pulley must be held to prevent its dropping into the motor compartment as spindle is removed.

NOTE: As the bearings leave the headstock frame, mark them on top with a pencil so it will be possible to reassemble the spindle unit in the same relation as originally assembled.

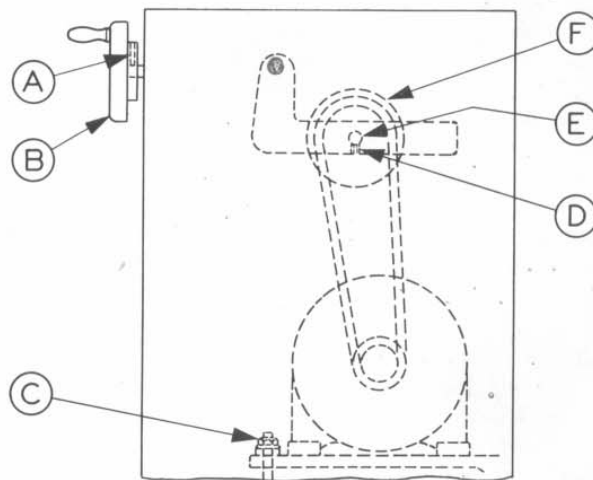
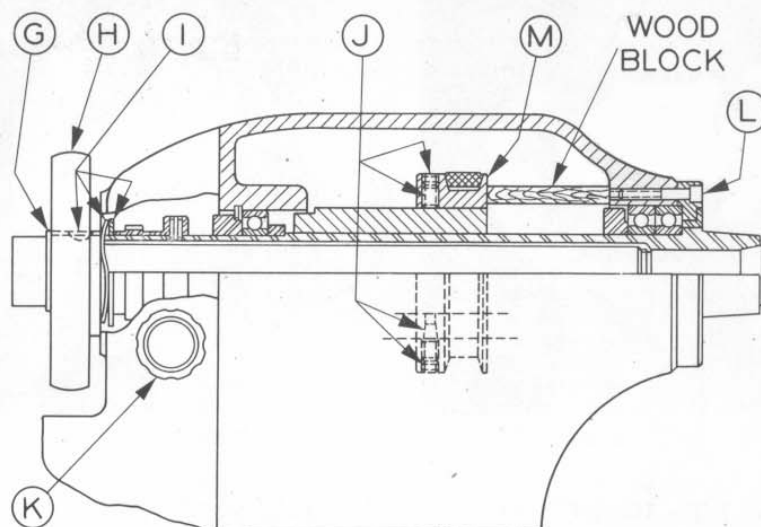

Figure 8

HOW TO CHANGE BELTS

The spindle of the Hardinge HLV Lathe is driven from the motor by two special matched endless V-belts. After considerable use, it may be necessary to apply new belts to the machine.

IMPORTANT: The headstock for machines with serial numbers in the Group 124 to 399 must be returned to the factory in Elmira, New York, for belt replacement as these units do not have a quill-type spindle to permit the changing of belts by users. **DO NOT ATTEMPT TO REMOVE THE HEADSTOCK SPINDLE ON THESE MACHINES.**

The following instructions and drawings on opposite page make changing of belts easy on machines having a serial number of HLV-400 or above:

TO REMOVE SPINDLE, SPINDLE BELT AND MOTOR BELT

1. With machine running, reduce spindle speed to 125 R.P.M. the lowest speed setting for variable speed indicator. Then stop machine.
2. Loosen set screw "A" and remove handwheel "B" to open door.
3. Remove nut "C" using a suitable pry bar to raise motor plate approximately 2" or enough to slip motor belt from motor pulley.
4. Loosen screw "D" and pull out pulley shaft "E".
5. Remove pulley assembly "F". This is done by first raising the pulley unit enough to remove spindle drive belt from pulley unit; then lowering pulley unit through the opening in the drive frame.
The motor belt can also be removed at this time.
6. Remove lever collet closer or draw bar from headstock spindle.
7. Remove cover from rear of head and pull spindle drive belt up through opening at rear of headstock.
8. Remove snap ring "G" with screw driver and pull handwheel "H" off end of spindle. Remove Woodruff key, wave washer and spacer "I".
9. Remove lock screw, taper set screw, and set screws "J" through opening in rear of head.
10. Place knob "K" to "Thread" position.
11. Remove the three socket head screws "L" from front cap.
12. Slide pulley "M" as far toward the rear of the spindle as possible. If pulley cannot be moved by hand, place wood block between pulley and front bearing boss as shown.
13. Tap on rear end of spindle with rawhide mallet while pulling the spindle assembly out from the front of the headstock frame. The spindle pulley must be held to prevent its dropping into the motor compartment as spindle is removed.

NOTE: As the bearings leave the headstock frame, mark them on top with a pencil so it will be possible to reassemble the spindle unit in the same relation as originally assembled.

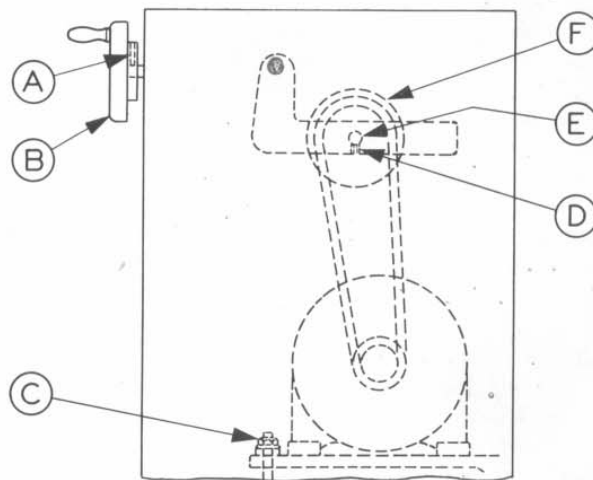
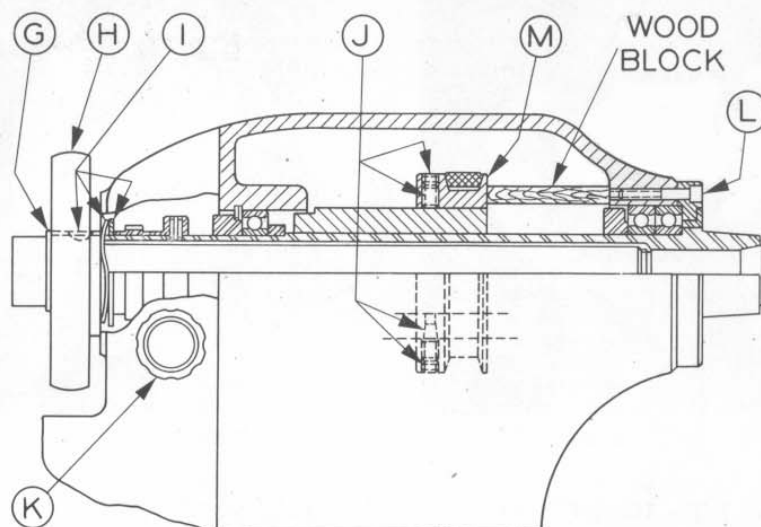

Figure 8

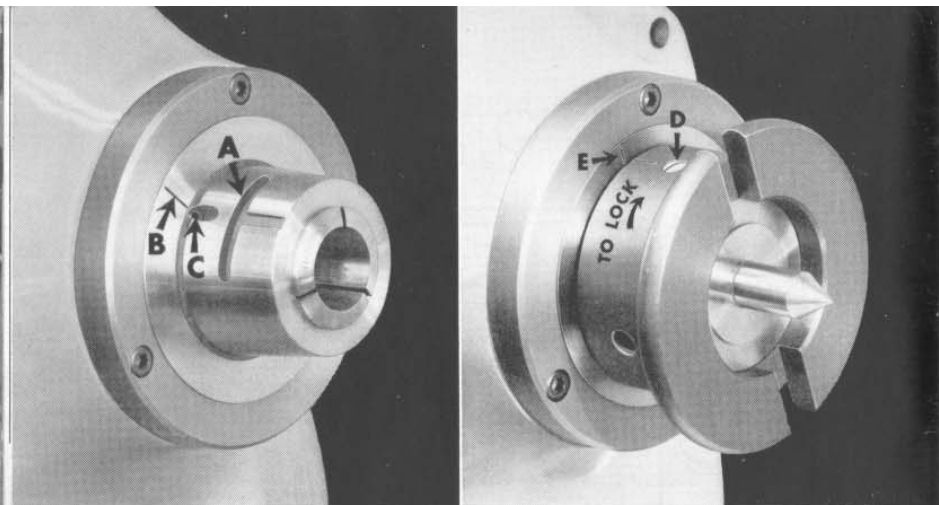

Figure 9

Figure 10

HOW TO APPLY AND REMOVE SPINDLE NOSE TOOLING

Figures 9 and 10

The Hardinge Taper Nose spindle construction is time-proven for accuracy, durability and for fast, easy application and removal of spindle nose tooling. The precision ground slow taper holds and aligns all tooling. The pin in all headstock spindle nose tooling engages the bayonet slot "A", to draw the attachment securely on the taper. Once securely drawn up, the spindle nose attachment is actually driven by the locking action of the tapered surface.

BEFORE APPLYING ANY ITEM OF TOOLING TO THE SPINDLE NOSE WIPE THE SPINDLE NOSE AND ATTACHMENT MATING SECTION CLEAN.

TO APPLY the drive plate for driving dog, for example, align key "D", Figure 10, with bayonet slot and slide drive plate on spindle nose. When it is back as far as it will go turn the drive plate clockwise to lock in place. Drive plate shown in Figure 10 is in the locked position. This is determined by the relation of the key "D" and spindle reference line "B". Final tightening should be done with a standard pin type spanner wrench. (Use Williams or Armstrong spanner wrench No. 460. Do not use hammer and punch.)

TO REMOVE the drive plate, turn counter-clockwise with spanner wrench to loosen. Continue to turn until key "D" is in line with reference mark "E", then remove from spindle by sliding to right off end of spindle.

IMPORTANT — to obtain accurate results from precision spindle nose attachment always be sure the spindle nose and mating section in attachment are **CLEAN BEFORE THEY ARE ASSEMBLED TOGETHER.**

DO NOT REMOVE KEY "D" TO REMOVE SPINDLE NOSE TOOLING. IT IS THE SLOW WAY AND WILL INTERFERE WITH FUTURE ACCURATE OPERATION OF THE ATTACHMENT.

SPINDLE COLLET KEY — Figure 9

The spindle collet key "C", Figure 9, can be removed and replaced, in the event of wear or damage, without removing the headstock, spindle or spindle bearings. Use a 3/32" hexagon pin wrench to remove lock screw; then remove collet key screw with same hexagon pin wrench.

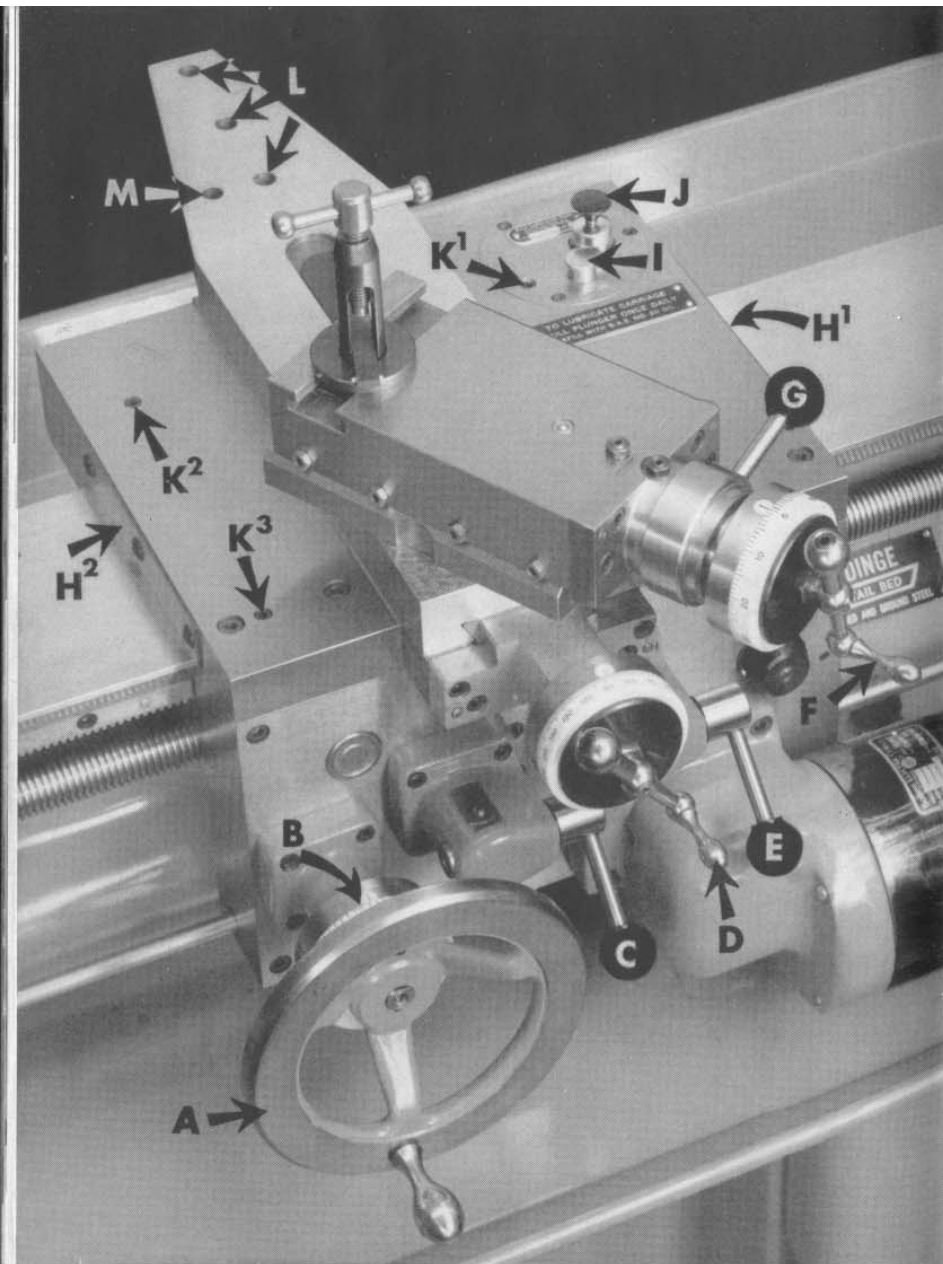

Figure 11

CARRIAGE AND APRON — Figure 11

CARRIAGE HANDWHEEL "A" is used to move carriage along bed by hand.

CARRIAGE HANDWHEEL DIAL "B" is made of a permanent white material for easy reading. Friction mounting for rapid, easy setting to zero. Graduations equal $.010''$.

LONGITUDINAL CARRIAGE FEED CLUTCH "C" controls the power feed for carriage along bed. To engage clutch raise ball handled lever to horizontal position. To release clutch press lever down to the position as shown in Figure 11.

CROSS FEED SCREW CRANK "D" is used for hand feeding cross slide. Black and white dial on cross slide feed screw is graduated in $.001''$ and is DIRECT READING. (Move the cross slide feed screw one graduation which is equal to $.001''$ and the cutting tool will remove $.001''$ from the diameter of the work). Dial has friction mounting for ease in setting to zero.

CROSS SLIDE FEED CLUTCH "E" controls the power feed for the cross slide. To engage the clutch raise the ball handled lever to the horizontal position. To release the clutch press the lever down to the position shown in Figure 11.

COMPOUND SLIDE FEED SCREW CRANK "F" is used to feed the compound slide. The black and white dial on the compound slide is graduated in $.001''$. The dial has a friction mounting for rapid, easy setting to zero.

QUICK ACTING HANDLE FOR COMPOUND SLIDE "G" is used when threading — see separate instructions on threading on Pages 38, 39, 40, 41 and 42.

CARRIAGE BED WIPERS "H" and "H2" are of hardened and ground steel mounted at both ends of the carriage.

(Continued on Page 24)

CARRIAGE AND APRON — continued from Page 23

PRESSURE LUBRICATOR RESERVOIR "I". Keep this pressure lubricator filled with Sunoco Way Lube—Socony Mobil GG Vactra Oil No. 2—or equivalent.

MAINTAIN APRON OIL LEVEL — in reservoir located at left hand side of apron with Gulf No. 667 — Socony Mobil Velocite Oil No. 6 or equivalent.

PRESSURE LUBRICATOR CONTROL "J". To lubricate carriage and bed ways pull plunger "J" up as far as it will go, then release and allow it to return of its own accord. Operate pressure oiler as often as required to keep the bed ways wet with oil.

FOLLOWER REST MOUNTING HOLES "K¹", "K²" and "K³" are mounting holes for follower rest. See Page 55 for instructions to mount follower rest.

HOLES FOR ATTACHING TAPER ATTACHMENT "L" — see separate instructions on Pages 56 and 57 for taper turning attachment.

HOLE FOR MOUNTING COOLANT ASSEMBLY "M" — see separate instructions on Pages 66 and 67.

CARRIAGE LOCK — Figure 12

The carriage lock "A" is used to hold the carriage in a fixed position on the bed when doing heavy facing operations or when accurate groove spacing is involved. The carriage lock handle "A" is shown in the unlocked position. Moving the ball handled lever toward the operator locks the carriage. With the dovetail bed design the carriage lock binds the front, back and top of the carriage securely to the bed.

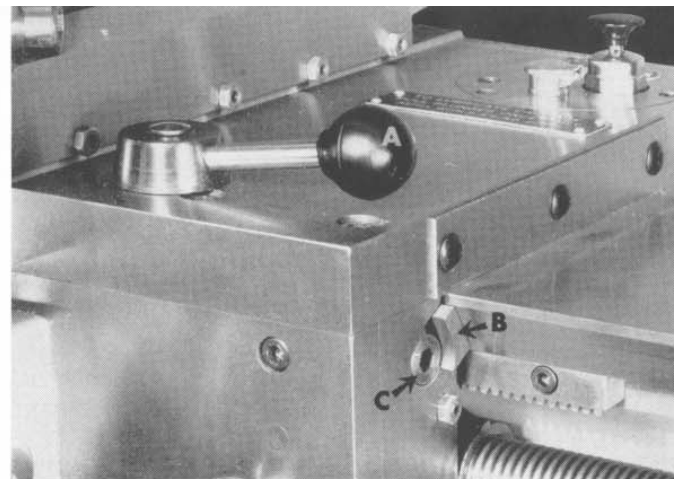

Figure 12

CARRIAGE GIB — Figure 12

After considerable use it may be necessary to adjust the carriage gib. The tapered gib "B" is adjusted and held from moving endwise by adjusting screw "C". There is another adjusting screw directly behind screw "C". These screws oppose each other to lock gib in place. The top screw "C" has a 1/4" hexagon opening through the screw. To tighten the gib, loosen the top screw one turn and then extend the 1/4" hexagon wrench through this screw into the second adjusting screw. With the wrench through both screws turn wrench part of a turn, then withdraw wrench from second adjusting screw and lock outer screw "C". Test gib adjustment by moving carriage with carriage hand-wheel. Repeat adjustment until desired gib adjustment is obtained. Excessive gib pressure or drag does not improve machine performance. Generally, it is best practice to tighten the gib a little on the tight side and then back off adjustment until proper carriage feel is obtained.

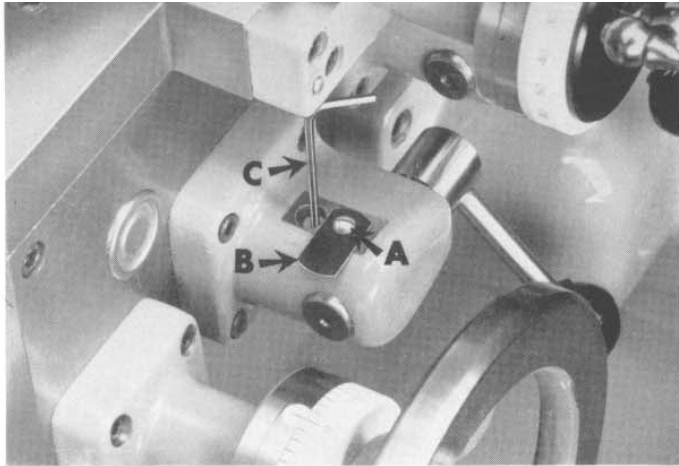

Figure 13

CARRIAGE AND CROSS SLIDE CLUTCH ADJUSTMENT

Figure 13

To adjust the longitudinal carriage feed clutch, loosen screw "A" and swing cover to position shown, exposing the opening through which clutch adjustment is made. Look down through the opening, with the power feed motor running, see Pages 28 and 29, and watch for an adjusting screw in the rotating collar within the clutch housing. When the adjusting screw is visible shut off the power feed motor. See separate instructions on power feed motor control on Pages 28 and 29.

Place a 1/8" hexagon wrench "C" into the hollow set screw and loosen screw. **CAUTION** — do not remove set screw — just loosen one turn and do not remove wrench.

Place power feed selector switch to move carriage to the "LEFT" then jog power feed motor by switching power feed "ON" and "OFF" with switch on power feed control panel. This will thread collar along the shaft, moving the clutch surfaces closer together.

To release or back the clutch surfaces further apart, jog the power feed motor to the "RIGHT".

Lock set screw and remove wrench. Test clutch under power. Several test adjustments may be necessary before desired clutch setting is obtained. Be sure to replace cover "B" to prevent dirt from entering clutch assembly.

To adjust the cross slide feed clutch, use the same procedure as with the longitudinal carriage feed clutch only reverse the jogging rotation. To move the cross slide clutch surfaces together, jog power feed motor to "RIGHT". To release or move clutch surfaces further apart, jog motor to the "LEFT".

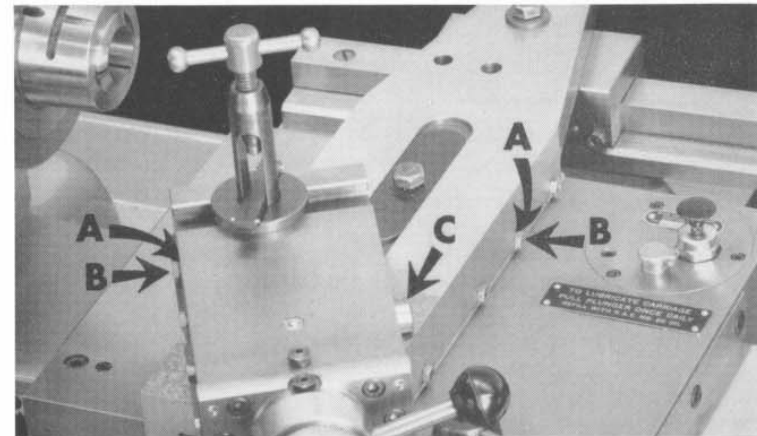

Figure 14

CROSS SLIDE AND COMPOUND SLIDE GIB ADJUSTMENT

Figure 14

To adjust the gib, loosen each gib screw lock nut "A". Then advance screw "B" until desired fit is obtained. Each of the five screws must be adjusted individually and the "drag" on the slide checked after each adjustment. Lock each nut "A" to retain setting of gib screws.

Follow the same procedure when adjusting the gib on the compound slide.

(Continued on Page 28)

COMPOUND SLIDE LOCK — Figure 14

The compound slide swivels for turning angles. To move the swivel base turn eccentric draw bolt "C", Figure 14, with 5/16" hexagon wrench. Set compound slide to the desired angle and lock securely with eccentric bolt "C". Turn clockwise to lock.

TO REMOVE CROSS SLIDE

It is good practice to occasionally remove the cross slide. To do this turn the cross slide feed screw ball handle clockwise until the slide comes off the back side of the carriage. With slide removed it is easy to lubricate cross feed screw and nut and to clean the slide ways. Use care when re-engaging the cross feed nut and screw. Bumping will bend the first thread of the nut causing it to bind on the screw.

POWER FEED FOR CARRIAGE — Figure 15

The carriage power feed is by a direct current, totally enclosed, ball bearing motor mounted on the carriage.

110 volt alternating current is fed from the main electric control panel at the left-hand end of the pedestal base to the power feed control panel at the right-hand end of the machine — see Figure 15. In the power feed control panel the current is converted by selenium rectifiers to direct current for the power feed motor. The electric cable from control panel to power feed motor is of oil resistant neoprene.

To start the power feed, position the "ON-OFF" toggle switch to the "ON" position. When this is done, the pilot light will light, showing that the panel is on. In the event the pilot light burns out, unscrew the red plastic shield from the face of the control panel and replace bulb with General Electric 1/25 watt Glow-Lamp No. NE51.

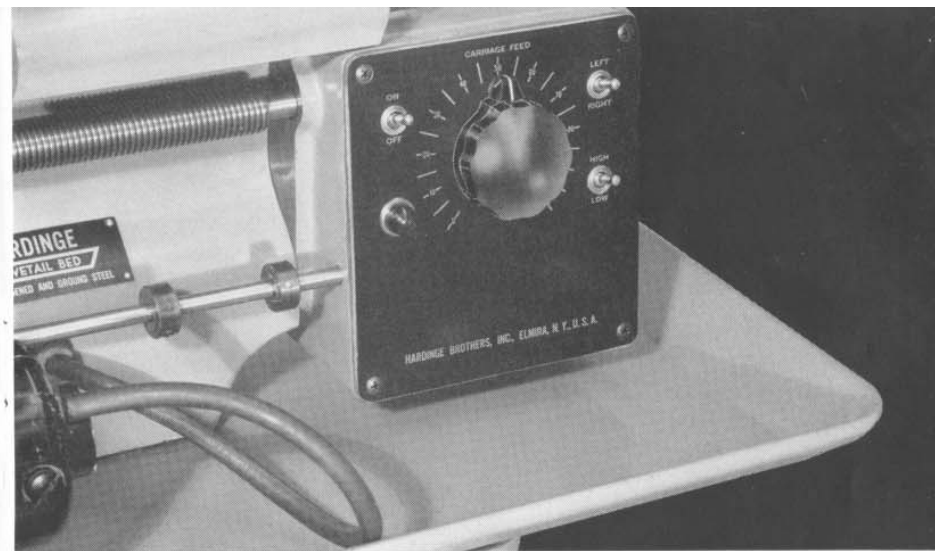

Figure 15

The "LEFT-RIGHT" toggle switch is used to reverse the power feed motor which reverses the direction of feed of carriage and cross slide. When placed in "LEFT" position the carriage will feed toward the left or headstock. When in "RIGHT" position carriage will feed toward right.

The "HIGH-LOW" toggle switch changes the speed of the power feed motor. This switch may be changed at any time without stopping the motor. The power feed motor and control panel are protected by a Fusetron in the main control panel at the left-hand end of the pedestal base. An extra Fusetron is provided in the electric control panel.

Specification of Fusetron is as follows:

Fusetron Buss No. MDL 1-1/4 Ampere

IMPORTANT: Use only Fusetron fuse.

The rate of carriage feed can be increased or decreased by turning feed control knob on control panel. The rate of feed to use is determined by material being cut, type of cutting tool used, and the work finish required. The rate of feed may be changed while the tool is cutting. The numbers on the dial are for repeat reference only.

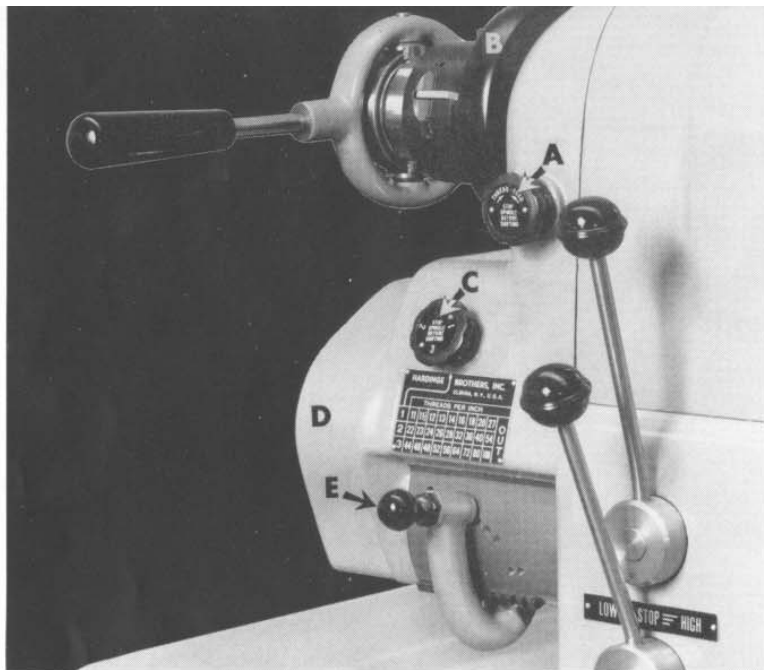

Figure 16

GEAR BOX FOR THREADING ONLY — Figure 16

Precision threading is an outstanding feature on the Hardinge HLV lathe. The logical separation of the power feed and lead screw gear box reserves the precision gear box for threading only, assuring maximum precision for the lead screw drive.

The all steel gears within the gear box run on shafts mounted on ball bearings. These bearings are grease packed and sealed, requiring no further attention.

TO ENGAGE GEAR BOX

To engage the gear box turn knob "A" clockwise in the direction of arrow marked "THREAD". When turning knob "A" the teeth of the sliding gear within the gear box may not mesh with the headstock spindle gear teeth. If so, turn the headstock spindle by means of spindle handwheel "B".

IMPORTANT: Before turning spindle release spindle brake to obtain free spindle — see instructions on Page 12. While turning spindle also turn knob "A" to right until a definite click is heard.

IMPORTANT: Knob "A" should always be set in the "Feed" position except when threading, thus disconnecting gear box from headstock spindle.

The Hardinge HLV Lathe quick change gear box permits instant selection of 27 different threads by shifting a lever and turning a knob.

Knob "C", or the change knob, Figure 16, has three numbered positions — 1, 2 and 3. These numbers correspond with the 1, 2 and 3 given at the extreme left side of the gear box thread chart plate. The tumbler or nine change handle "E" has nine positions — each lining up with gear box thread chart plate. Combining the three positions of the three change knob and nine positions of the tumbler handle, 27 changes are obtained.

THREE CHANGE KNOB — Figure 16

When number one of knob "C" is in line with the arrow, any thread in row one of thread chart can be selected by changing the tumbler handle or nine change handle "E" to the desired thread in that row.

The three change knob "C" controls a sliding gear cluster. Number three on the knob, when lined up with the arrow on gear box chart, is in the center position. To place knob "C" in the number one position, turn to "RIGHT". Turn to "LEFT" to place number two position in line with arrow.

In the event the slide gear cluster does not engage the other gears in the gear box properly to bring the desired number on three change knob "C" in line with arrow, open the change gear cover "D" and turn shaft "A", Figure 17, see Page 33, by hand until gears mesh properly.

(Continued on Page 32)

TUMBLER HANDLE OR NINE CHANGE HANDLE

Figure 16

To make a selection on the gear box thread chart, pull the spring pressured black knob "E" out as far as it will go and lower until it will move sidewise to the desired notch directly under the thread required. Raise the handle and let plunger drop into hole. If the tumbler handle will not raise far enough to drop plunger into hole, open change gear cover and rotate shaft "A", Figure 17, see opposite page, until gears mesh and handle raises permitting plunger to seat.

At the extreme right on the gear chart is an "OUT" position which is used when change gears are set up outside the gear box for cutting threads not obtained within quick change gear box.

Fastened to the tumbler handle bracket within the gear box is a 5/16" round safety bar "C", Figure 17, that extends out through a hole in the left side of the gear box. This bar is to prevent applying change gears outside the gear box until the tumbler handle is placed in the "OUT" position.

IMPORTANT

Shift gears only when the machine is not running. The Hardinge HLV Lathe is a smooth running high speed machine and shifting of gears on the gear box when the machine is running will result in damage to the unit.

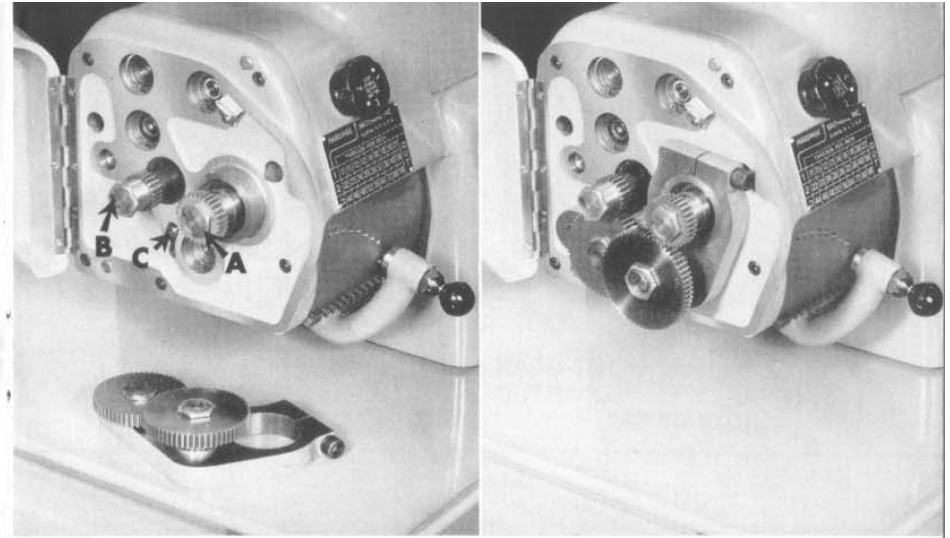

Figure 17

Figure 18

OUTSIDE CHANGE GEARS — Figures 17 and 18

The outside change gears are used to cut threads not provided in the quick change gear box. A set of five gears and a bracket are standard equipment with each machine. These gears, when set up to the gear chart — see Page 34, will cut 10 threads per inch. Three of the gears are shipped on the bracket and the other two are in place on the shafts as shown in Figure 17; one on the end of the lead screw shaft "A", and the other on the end of the sliding cluster gear shaft "B".

Before setting up change gears, place tumbler in the "OUT" position.

The tumbler gear handle or nine change handle has an interlock arrangement "C" so the outside change gears cannot be engaged unless the tumbler gear handle is in the "OUT" position.

To cut other threads which are not in the gear box, additional gears must be purchased — see Pages 34, 35, 36 and 37 where gearing charts are given for threads from 10 to 250 threads per inch.

IMPORTANT: — With spindle oil lubricate bushings and shafts on change gear bracket each time a set up is made. If long run threading is involved, lubricate daily.

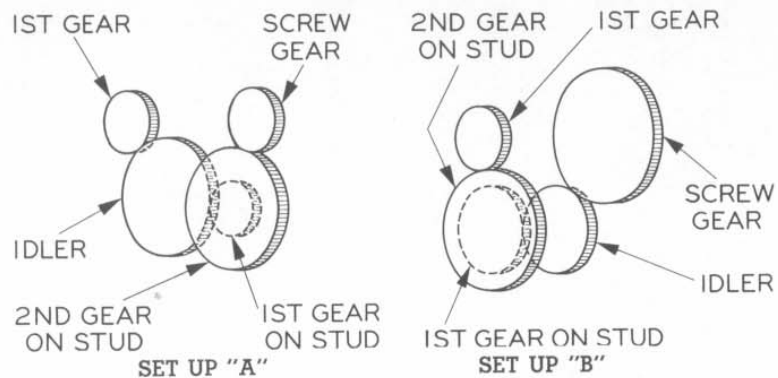

THREADS PER INCH	SET UP	KNOB	FIRST GEAR	FIRST GEAR ON STUD	SECOND GEAR ON STUD	SCREW GEAR	IDLER
10	A	2	22*	22*	60*	30*	55*
11				GEARBOX			
11½				GEARBOX			
12				GEARBOX			
13				GEARBOX			
14				GEARBOX			
15	A	1	40	None	30	60	44
16				GEARBOX			
17	A	1	40	34	30	60	44
18				GEARBOX			
19	A	1	40	38	30	60	44
20				GEARBOX			
21	A	1	40	42	30	60	44
22				GEARBOX			
23				GEARBOX			
24				GEARBOX			
25	A	1	40	50	30	60	30
26				GEARBOX			
27				GEARBOX			
28				GEARBOX			
29	A	1	40	58	30	60	30
30	A	2	40	None	30	60	44
31	A	1	30	31	22	66	44

* Five gears supplied as standard equipment with machine.

THREADS PER INCH	SET UP	KNOB	FIRST GEAR	FIRST GEAR ON STUD	SECOND GEAR ON STUD	SCREW GEAR	IDLER
32				GEARBOX			
33	A	1	30	33	22	66	44
34	A	1	30	34	22	66	44
35	A	1	30	35	22	66	44
36				GEARBOX			
37	A	1	30	37	22	66	44
38	A	2	40	38	30	60	44
39	A	1	30	39	22	66	44
40				GEARBOX			
41	A	1	30	41	22	66	44
42	A	2	40	42	30	60	44
43	A	1	30	43	22	66	44
44				GEARBOX			
45	A	1	30	45	22	66	44
46				GEARBOX			
47	A	1	30	47	22	66	44
48				GEARBOX			
49	A	1	30	49	22	66	44
50	A	2	40	50	30	60	30
51	A	1	30	51	22	66	44
52				GEARBOX			
53	A	1	30	53	22	66	44
54				GEARBOX			
55	A	1	30	55	22	66	44
56				GEARBOX			
57	A	1	30	57	22	66	40
58	A	2	40	58	30	60	30
59	A	1	30	59	22	66	40
60	A	3	40	30	30	60	44
61	A	2	40	61	30	60	40
62	A	2	30	31	22	66	44
63	A	2	40	42	22	66	44
64				GEARBOX			
65	A	2	48	52	22	66	30
66	A	2	30	33	22	66	44
67	B	2	30	40	60	67	40
68	A	2	30	34	22	66	44

THREADS PER INCH	SET UP	KNOB	FIRST GEAR	FIRST GEAR ON STUD	SECOND GEAR ON STUD	SCREW GEAR	IDLER	
69	A	2	40	46	22	66	44	
70	A	2	30	35	22	66	44	
71	A	3	60	33	22	71	30	
72				GEARBOX				
73	A	3	60	33	22	73	30	
74	A	2	30	37	22	66	44	
75	A	2	40	50	22	66	44	
76	A	3	40	38	30	60	44	
77	A	3	60	33	22	77	30	
78	A	2	30	39	22	66	44	
79	A	3	60	33	22	79	30	
80				GEARBOX				
81	A	3	40	27	22	66	44	
82	A	2	30	41	22	66	44	
83	B	3	22	60	83	33	55	
84	A	3	40	42	30	60	44	
85	A	2	24	34	22	66	44	
86	A	2	30	43	22	66	44	
87	A	3	40	29	22	66	44	
88	A	2	30	44	22	66	44	
89	B	3	22	60	89	33	55	
90	A	2	30	45	22	66	44	
91	B	3	22	60	91	33	30	
92	A	2	30	46	22	66	44	
93	A	3	40	31	22	66	44	
94	A	2	30	47	22	66	44	
95	A	2	24	38	22	66	44	
96	A	2	30	48	22	66	44	
97	B	3	22	60	97	33	55	
98	A	2	30	49	22	66	44	
99	A	3	40	33	22	66	44	
100	A	3	40	50	30	60	30	
102	A	2	30	51	22	66	44	
104	A	2	30	52	22	66	44	
105	A	2	24	42	22	66	44	
106	A	2	30	53	22	66	44	
108				GEARBOX				

THREADS PER INCH	SET UP	KNOB	FIRST GEAR	FIRST GEAR ON STUD	SECOND GEAR ON STUD	SCREW GEAR	IDLER
110	A	2	30	55	22	66	44
112	A	2	30	56	22	66	40
114	A	2	30	57	22	66	40
115	A	2	24	46	22	66	44
116	A	3	40	58	30	60	30
118	A	2	30	59	22	66	40
120	A	2	30	60	22	66	40
122	A	3	40	61	30	60	40
124	A	3	30	31	22	66	44
125	A	2	24	50	22	66	44
126	A	3	40	42	22	66	44
128	A	3	30	32	22	66	44
130	A	3	48	52	22	66	30
132	A	3	30	33	22	66	44
134	B	3	30	40	60	67	40
135	A	3	40	45	22	66	44
136	A	3	30	34	22	66	44
138	A	3	40	46	22	66	44
140	A	3	30	35	22	66	44
142	B	3	22	60	71	66	30
144	A	3	40	48	22	66	44
145	A	3	48	58	22	66	30
146	B	3	22	60	73	66	30
148	A	3	30	37	22	66	44
150	A	3	40	50	22	66	44
160	A	3	24	32	22	66	44
170	A	3	24	34	22	66	44
180	A	3	30	45	22	66	44
190	A	3	24	38	22	66	44
200	A	3	24	40	22	66	44
210	A	3	24	42	22	66	44
220	A	3	30	55	22	66	44
230	A	3	24	46	22	66	44
240	A	3	30	60	22	66	40
250	A	3	24	50	22	66	44

INSTRUCTIONS FOR THREAD CUTTING

ON

HARDINGE HLV LATHE

The Hardinge HLV Lathe is designed for rapid and accurate thread cutting. Threads can be cut to a shoulder without fear of running into the shoulder since the automatic stops will stop the carriage at a pre-determined point in either direction.

Before starting to cut a thread, select the proper cutting speed for the size of thread to be cut and to give the best finish for the particular material being used. Maximum recommended threading speed is 1000 r.p.m.

Set quick change gear box or outside change gears for desired pitch.

Set compound slide at desired angle and position cutting tool in compound slide tool post.

Set left carriage stop "A", Figure 19, and right carriage stop "B", Figure 20, in approximate position. Engage lead screw nut "C" by moving ball handled lever "D" from a vertical position to position shown.

CAUTION: Lock carriage stops securely before starting to cut threads. Do not release carriage nut "C" until threading operation is completed. **Do not use carriage stop when headstock spindle is running in reverse.**

Carriage control lever "B", Figure 1, Page 11, when moved to the left will cause carriage to move to the left. When the carriage control lever is moved to the right the carriage will move to the right. Carriage can be stopped manually at any time by placing carriage control lever in the center position as shown in Figure 1.

LEFT HAND THREADS—can be cut the same as right hand except cutting pass is made from the headstock toward the tailstock. Carriage control stops are used for left hand threads the same as right hand threads.

(continued on page 40)



Figure 19

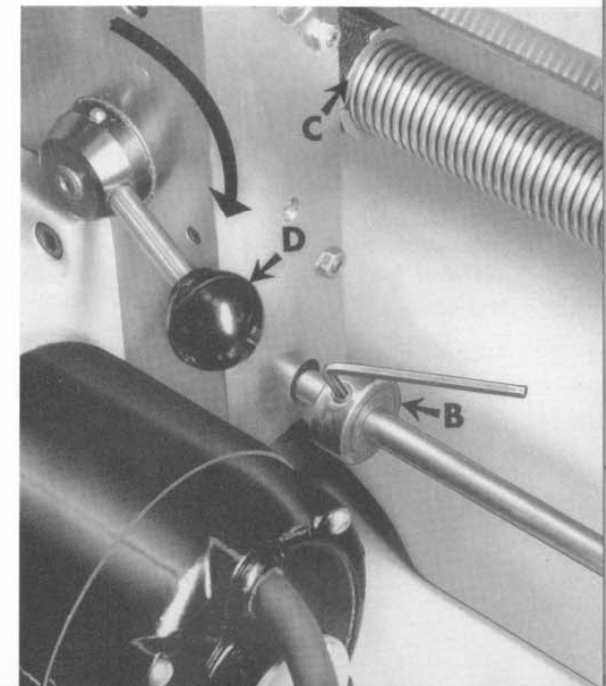

Figure 20

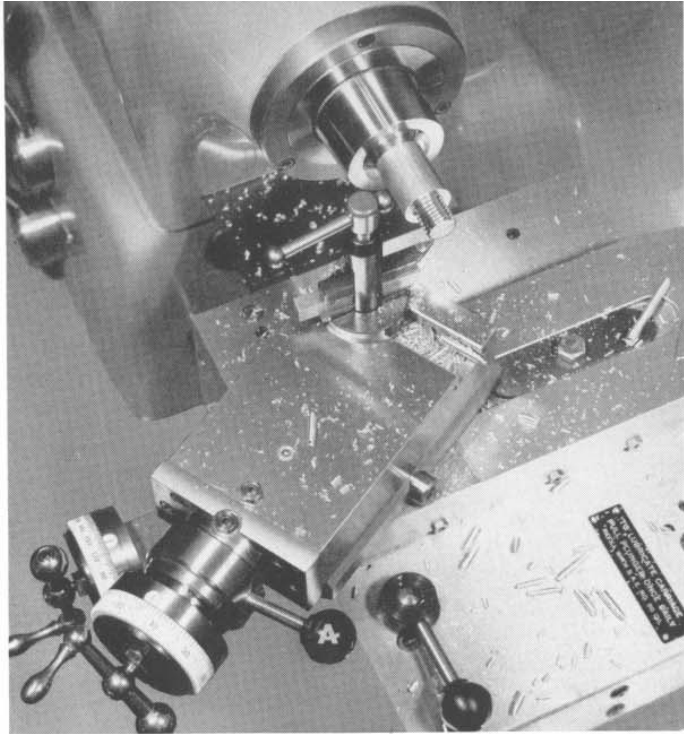

Figure 21

THREAD CUTTING — continued

The illustration above shows the threading tool in the correct position to start a threading pass. The carriage stop controlling the travel of the carriage to the right or toward the tailstock end of the machine has been properly set. This setting should always place the tool a short distance from the end of the work — excessive distance from end of work slows the complete threading operation.

When carriage is at rest and quick acting handle "A" is to the right in the cutting position, feed the cutting tool in the desired number of thousandths for the next threading pass.

Move lever "B", Figure 1, to the left and carriage will start and move until it contacts stop at headstock end of machine stopping carriage as shown in Figure 22.

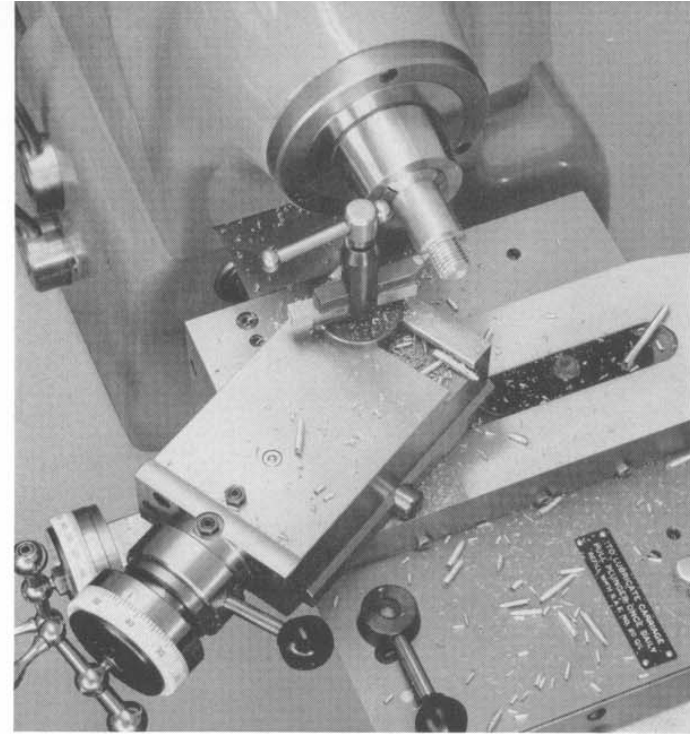

Figure 22

THREAD CUTTING — continued

This illustration shows the cutter and carriage at the end of the threading pass. Notice that the threading tool is close to the shoulder — the carriage was stopped in this position by the carriage stop which controls the lead screw. Headstock spindle continues to run in the forward direction. Carriage stops cause only the gear box, lead screw and carriage to stop running.

When cutting left-hand threads, start the threading pass next to the shoulder and make the threading pass toward the tailstock.

(Continued on Page 42)

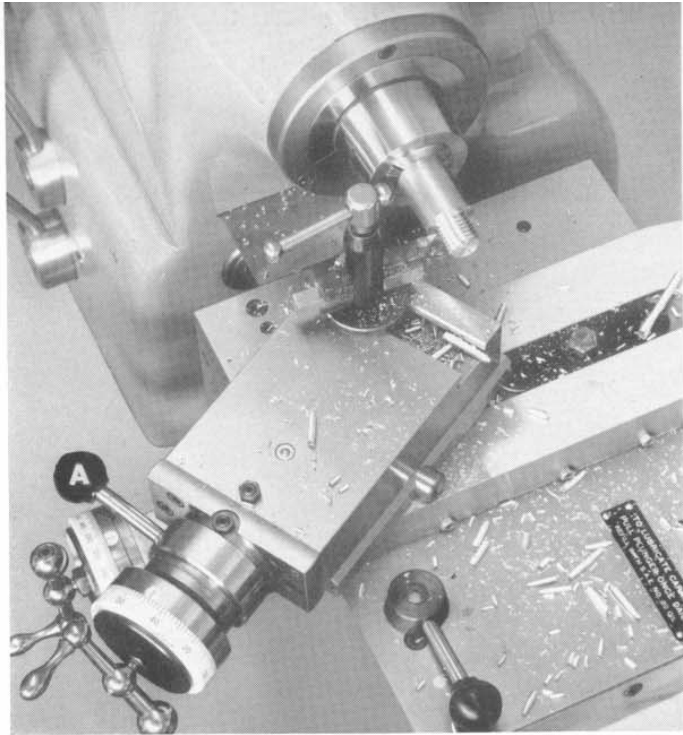

Figure 23

THREAD CUTTING — continued

Illustrated above is the carriage in the same position on the bed as in Figure 22 only that quick acting handle "A" on the compound slide has been moved to the left withdrawing tool from work. After withdrawing tool with quick acting handle, the carriage is reversed or moved to the right to the starting position by moving carriage control lever "B", Figure 1, to the right.

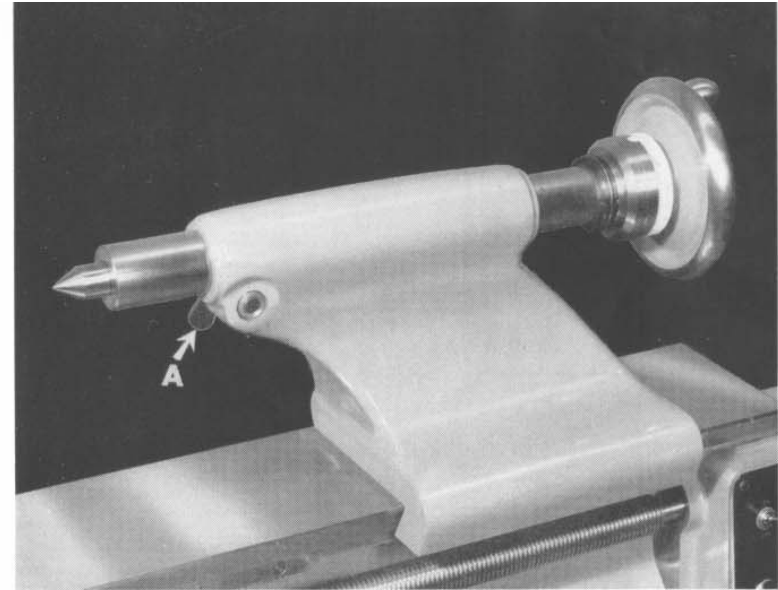

Figure 24

TAILSTOCK

The tailstock is securely anchored to the dovetail bed by means of a mating dovetail section and clamp at the back.

The hardened and ground spindle has 1/8" graduations for the full 3-1/2" travel. The handwheel has a black and white friction adjustable dial reading in .001" increments. The spindle takes standard No. 2 Morse taper shank centers and other tailstock tooling — see Pages 61, 62 and 63.

The spindle can be locked in any position by locking lever "A".

It is good practice to occasionally remove the tailstock from the machine. Turn the tailstock upside down and flush the feed screw with spindle oil through the opening in the bottom of the spindle. This will also lubricate the feed screw nut. It is also advisable to put a few drops of spindle oil on the outside of the tailstock spindle and wipe the oil around the entire spindle.

FLOOR PLAN

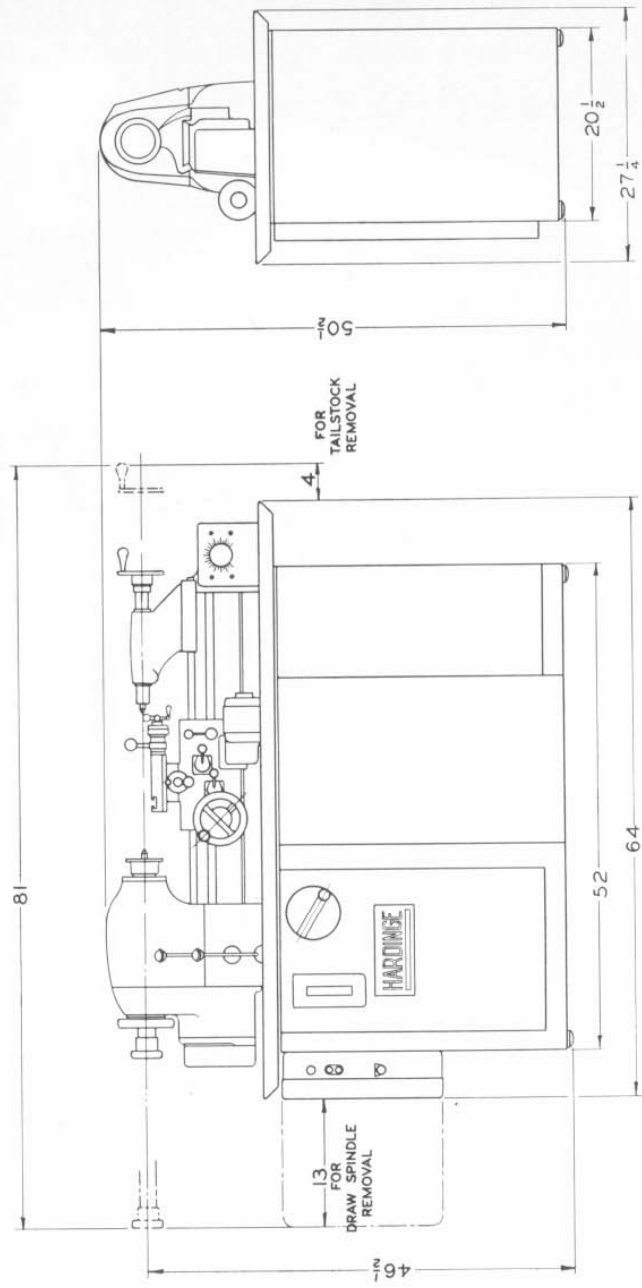

TOOLING

(Extra Equipment)

The next twenty-two pages cover standard tooling available for the Hardinge HLV Lathe.

All items of tooling can be either ordered with the machine or at a later date. Standard tooling is carried in stock. When ordering, specify item by name as listed in this book and give machine serial number.

HEADSTOCK SPINDLE TOOLING

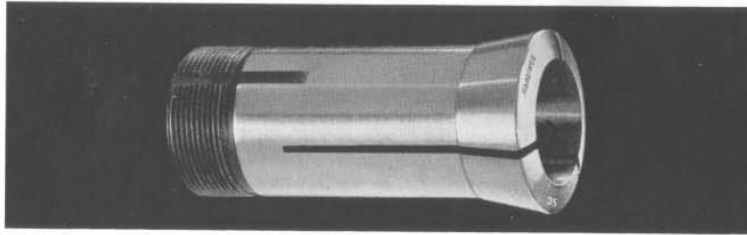

5C HARDINGE COLLETS

The Hardinge HLV Lathe takes 5C HARDINGE collets with capacity of 1" round, 7/8" hexagon and 3/4" square. Hardinge precision collets are manufactured to exact precision standards, and are available in all types and sizes for all makes of lathes and milling machines, as well as our own precision machines.

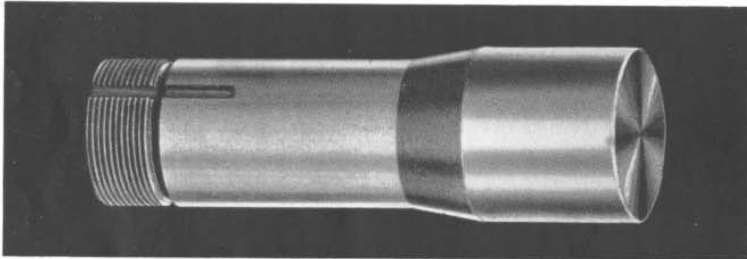

5C HARDINGE PLUG CHUCK

The collet shank section is finished for direct application to your machine spindle. The nose section is 1-15/32" in diameter and 1-3/4" long. It can be machined in place for the greatest degree of accuracy to suit your particular requirements for special arbors.

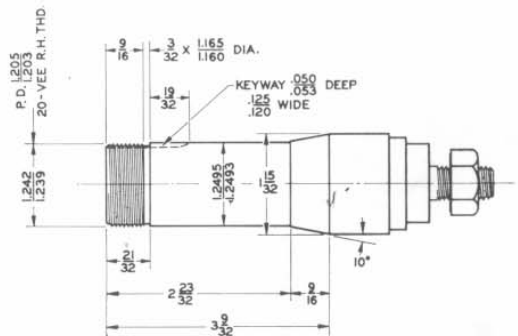

COLLET FIXTURE DIMENSIONS

HEADSTOCK SPINDLE TOOLING

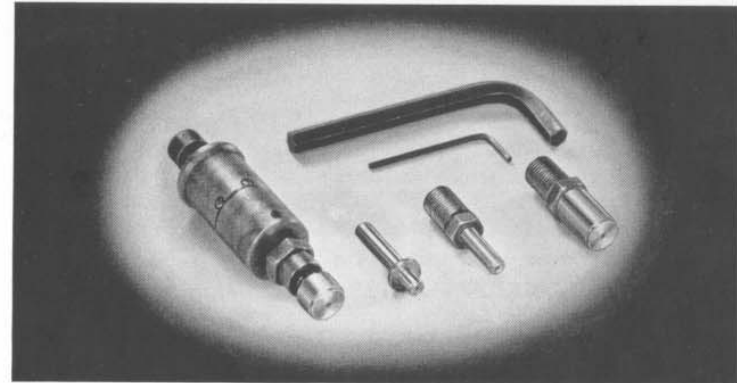

UNIVERSAL COLLET STOP

This stop converts 5C HARDINGE collets into solid stop or spring ejector stop collets, without alteration of the standard collets. The application of this stop to the collet requires no machining. In other words, all collets used with this machine can be used in the regular manner or as solid stop collets or as spring ejector stop collets.

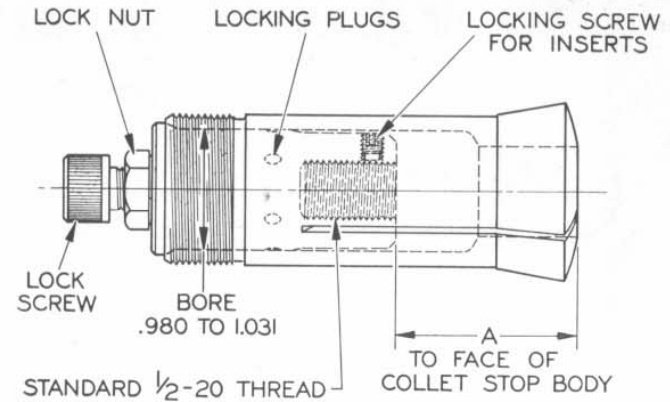

Dimension "A" is equal to 1-3/8" and is the maximum depth a part may be chucked using a solid stop. The maximum depth for spring ejector stop is 13/16". This is due to space required for spring ejector construction.

HEADSTOCK SPINDLE TOOLING

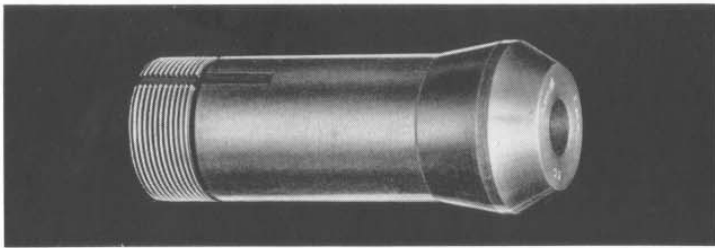

5C HARDINGE TAPER HOLE COLLETS

Hardinge 5C taper hole collets are hardened and precision ground for direct application to the headstock spindle. Available with No. 1 or 2 Morse Taper, 4, 5, 6 or 7 Brown & Sharpe Taper.

Taper hole collets are useful in making tools having tapered shanks and also when regrinding tailstock center.

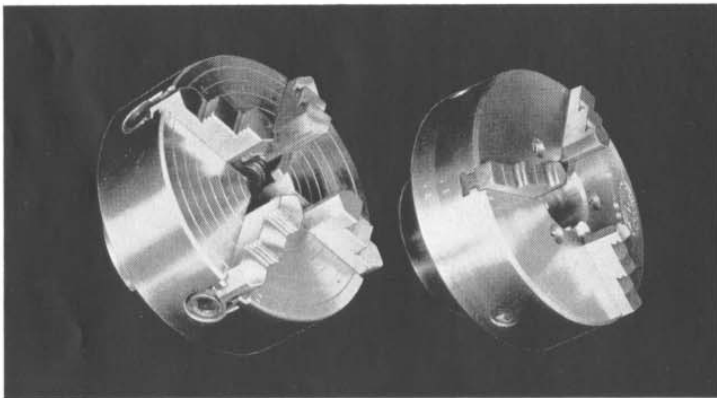

JAW CHUCKS*

Hardinge HLV Lathe is supplied with a taper nose headstock spindle for rapid accurate mounting of jaw chucks and other spindle nose attachments.

The 5" capacity four jaw and 5" capacity three jaw chucks, shown above, are available for use with the HLV Lathe.

These chucks are integrally mounted for direct application to the taper nose spindle, thus eliminating a separate mounting plate.

* When ordering, specify for taper nose spindle and give machine serial number.

HEADSTOCK SPINDLE TOOLING

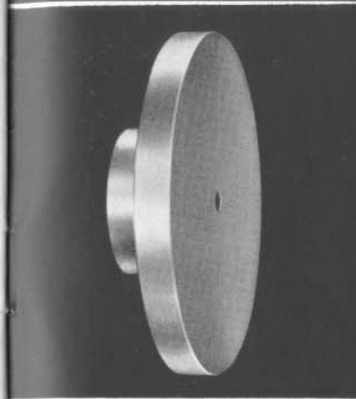

FIXTURE PLATES*

The fixture plate is machined all over for direct application to the headstock spindle. Three sizes are available; 3", 5" and 8-7/8" diameter. The flange section is 3/4" thick with a 7/16" center hole.

This plate can be machined to become a fixture or for mounting fixtures to hold work or for mounting special purpose chucks.

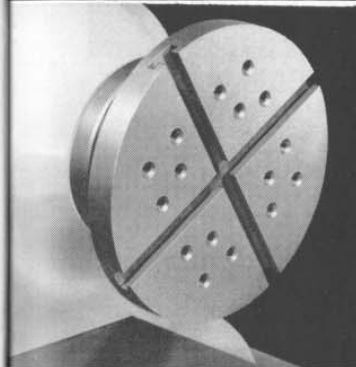

7" and 9" SLOTTED and

TAPPED FACE PLATES*

Are used for holding irregular shaped pieces. Holes are drilled and tapped to permit the use of standard 5/16 x 18 bolts.

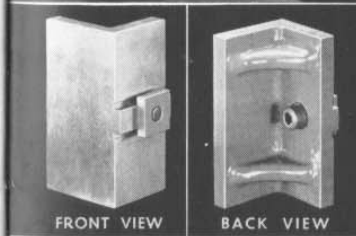

ANGLE PLATE FOR FACE PLATE

The angle plate fastens directly to the T-slot of the face plate and is used to support work at right angle to the face plate. Work clamping surface is 1-1/2" x 3".

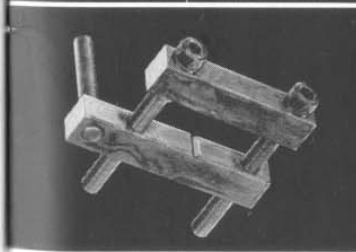

DRIVING DOG

The driving dog is used in conjunction with the drive plate to drive work between centers — see illustration at top of Page 3.

* When ordering, specify for taper nose spindle and give machine serial number.

HEADSTOCK SPINDLE TOOLING

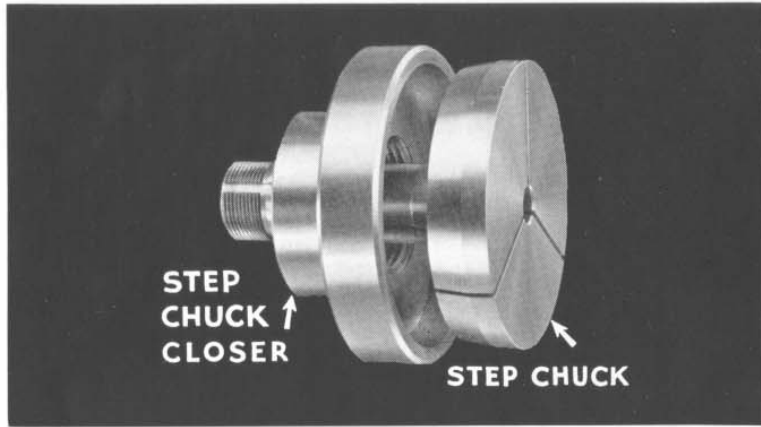

5C HARDINGE STEP CHUCKS

A step chuck is exceptionally useful for accurately holding work larger than 1" in diameter up to 6" in diameter. Tubing can be held without crushing or distorting. The step chuck will also hold castings, moldings, stampings and machined parts rigidly and accurately. The standard ball bearing lever operated collet closer is used to close the step chuck. The step chuck is closed by the taper on the periphery seating in the taper of the closer.

We carry 2", 3", 4", 5" and 6" step chucks and closers for all Hardinge headstocks. They are 3/8" larger in diameter than the rated size, so the full capacity step may be readily applied. Step chucks may be purchased in finished form, split only, or split and stepped to specifications.

Many users purchase step chucks, split only, and then apply the desired steps while the step chuck is in place on the machine, assuring dead accuracy of the steps in relation to the headstock spindle.

STEP CHUCK CLOSERS*

A closer is required for each size step chuck. The closer fits directly to the machine spindle and has a taper corresponding to the taper on the periphery of the step chuck for closing the step chuck. A step chuck closer is required for each nominal size step chuck to place the closing pressure over the stepped area of the chuck, resulting in greater gripping power and accuracy.

With locating pins applied in the step chuck closer and with clearance holes for the pins drilled in the step chuck, work may be held to predetermined length.

* When ordering, specify for taper nose spindle and give machine serial number.

HEADSTOCK SPINDLE TOOLING

ADVANTAGES OF USING STEP CHUCKS

Step chucks, developed by precision instrument makers, are a time proven method of holding work, rigidly and accurately. Step chucks take over on sizes above the regular collet capacity, providing collet-like accuracy, convenience, and precision results as with collets.

WHEN USING STEP CHUCKS: Analytical consideration of the gripping pressure applied on the work by a step chuck clearly shows one of the advantages of using step chucks. Note how

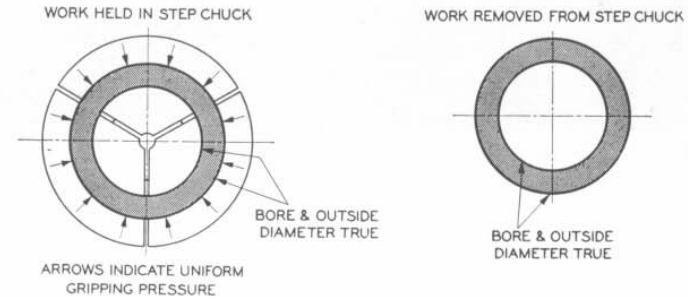

the gripping pressure is uniformly distributed over the entire circumference of the work. The large gripping area prevents distortion and eliminates marking of the work.

WHEN USING JAW CHUCKS: Studied consideration of the gripping pressure applied on the work by a jaw chuck clearly shows the disadvantage of using jaw chucks for precision work.

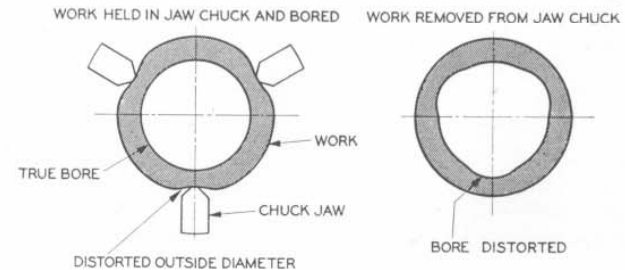

Note how the localized gripping pressure of the jaws distorts the work. The small area of the gripping surface of the chuck jaws will also mark the surface of the work.

INSTRUCTIONS FOR "STEPPING OUT" STEP CHUCKS

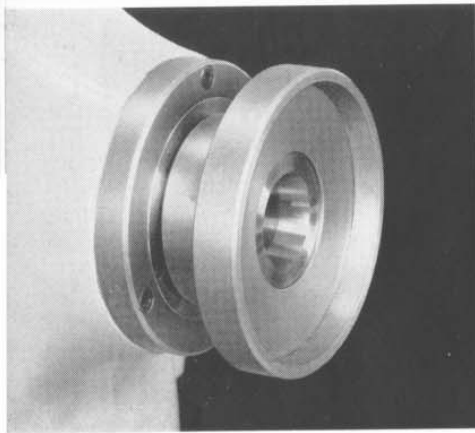

1. Clean taper nose spindle. Clean bore of step chuck closer. Apply closer to headstock spindle and tighten closer with spanner wrench. (Use Williams or Armstrong spanner wrench No. 460). **Do not use punch and hammer.**

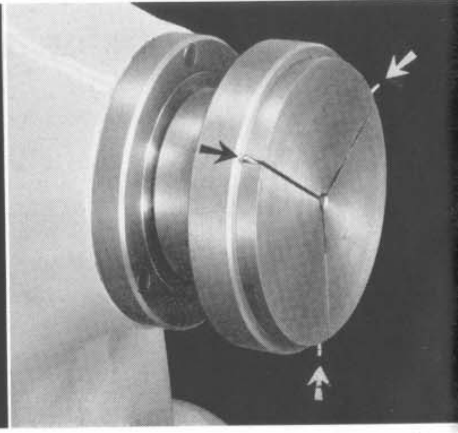

2. Clean inside of headstock spindle and outside of step chuck. Apply step chuck to spindle and collet closer. With step chuck in open position insert three 1/16" diameter wires or shims at outer edges of slots. Close step chuck — be sure wires or shims are securely held by step chuck.

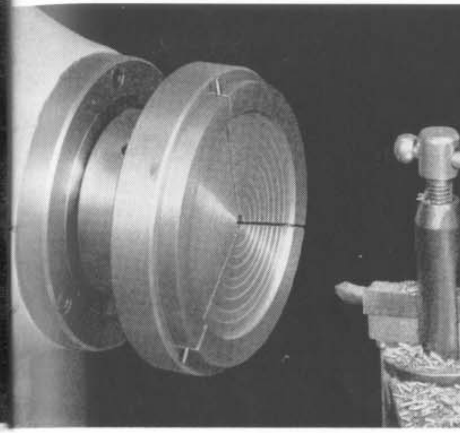

3. With sharp carbide boring tool, rough bore step chuck to approximate size. The step chuck may be rapidly bored on the HLV Lathe by using the plunge cut stepping method.

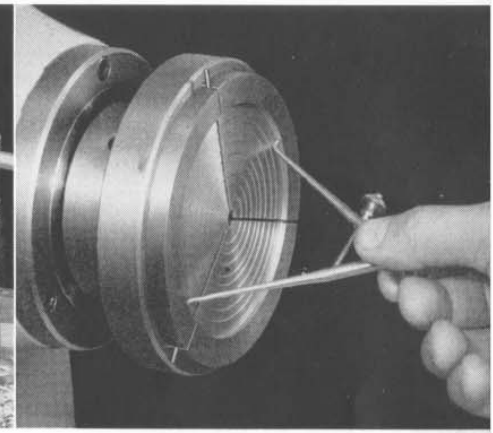

4. "Stepping out" of a step chuck requires care that bore is not oversize. When "roughing-out" use calipers, set slightly smaller than required size, to check bore diameter.

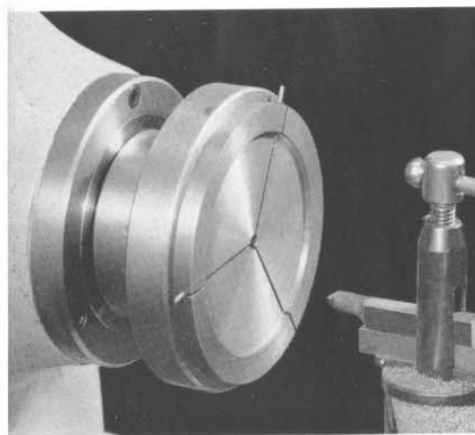

5. Finish bore to exact size of part to be held. Face bottom of bore in step chuck. If section of part to be held has a sharp corner, undercut corner of bore in step chuck.

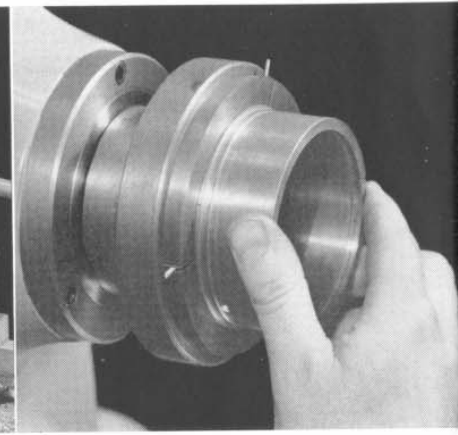

6. Clean bore of step chuck and use part as gage. Part should fit into step chuck like a good precision plug gage fit.

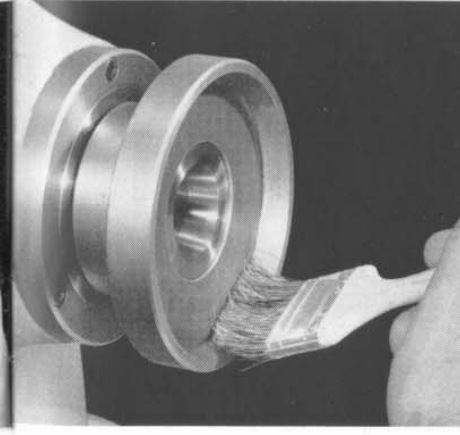

7. Remove step chuck. Clean step chuck closer and spindle. Wipe a few drops of oil on angle of step chuck closer and inside spindle. Perform this operation occasionally during a production run to assure accuracy of step chucks.

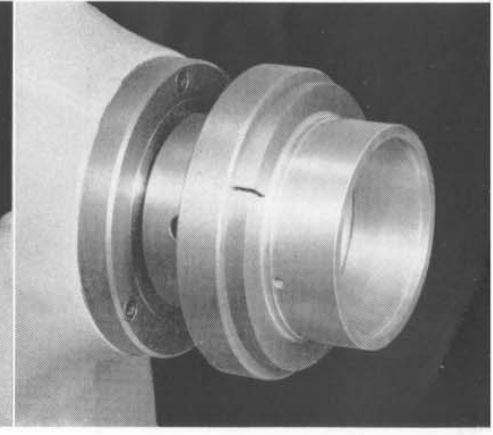

8. Remove pins or shims from slots of step chuck. Clean each slot of step chuck of all chips and apply step chuck to machine spindle. Adjust lever closer or draw spindle for tension and you are ready to run production.

CARRIAGE TOOLING

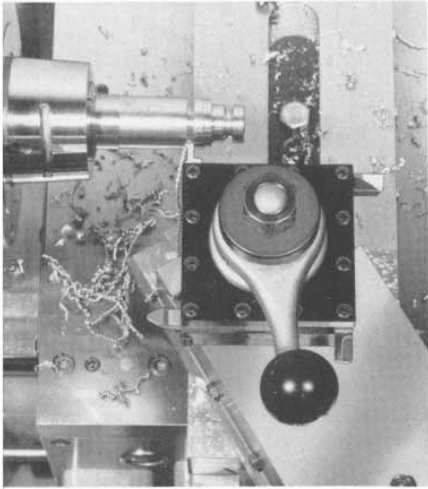

AUTOMATIC SQUARE INDEXING TURRET

The square turret is applied directly to the tool post T-slot of the compound slide. The turret takes standard 5/16" square tool bits. By a simple movement of the ball-handled lever, the turret is automatically unlocked, indexed to the next tool position and automatically relocked, ready for the next machining operation. Accurate indexing is accomplished through a hardened and precision ground tapered index pin.

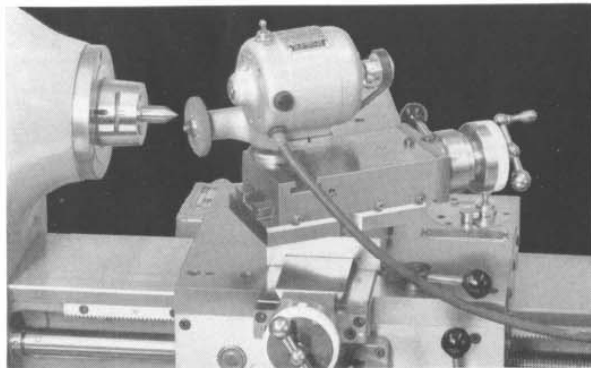

MOTOR GRINDER

The motor grinder unit mounts directly to the compound slide T-slot. It can be used for both external and internal grinding. Motor operates on 110 volt, single phase current. When grinding, keep as much of the bed, carriage and apron as possible covered with oil-soaked cloths to prevent abrasive material from causing injury to machine.

CARRIAGE TOOLING

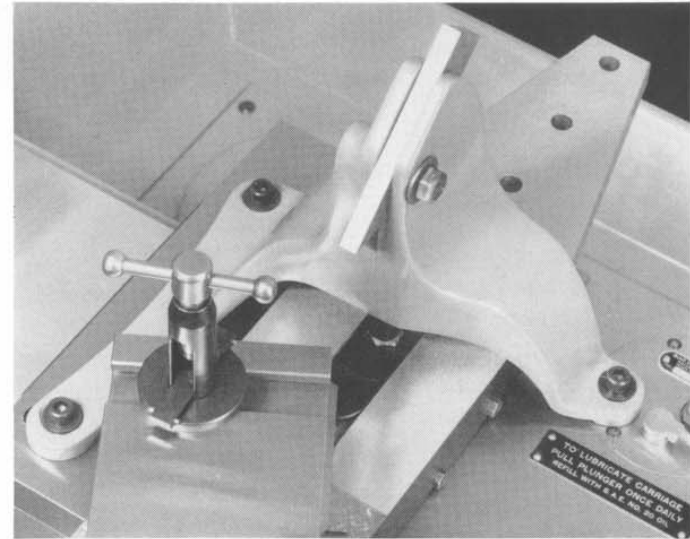

FOLLOWER REST

The follower rest is mounted directly to the carriage and is used to support work which, because of its small diameter in relation to length, may spring away from the cutting tool.

To apply the follower rest to the carriage remove plug screws indicated as K¹, K², K³, Figure 11, Page 22. Be sure to replace the screws after using follower rest as they keep holes free of chips and will make it easier to mount follower rest the next time it is required.

The jaw of the follower rest is adjustable to suit the work diameter.

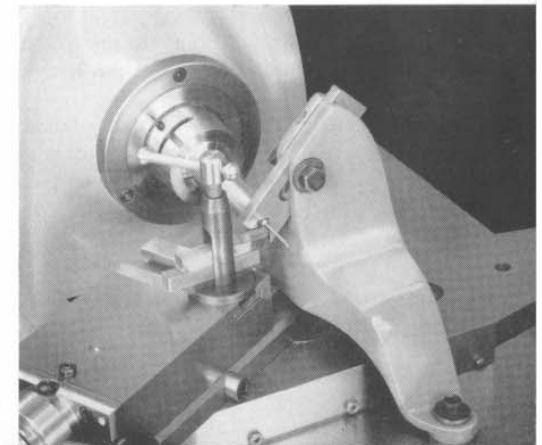

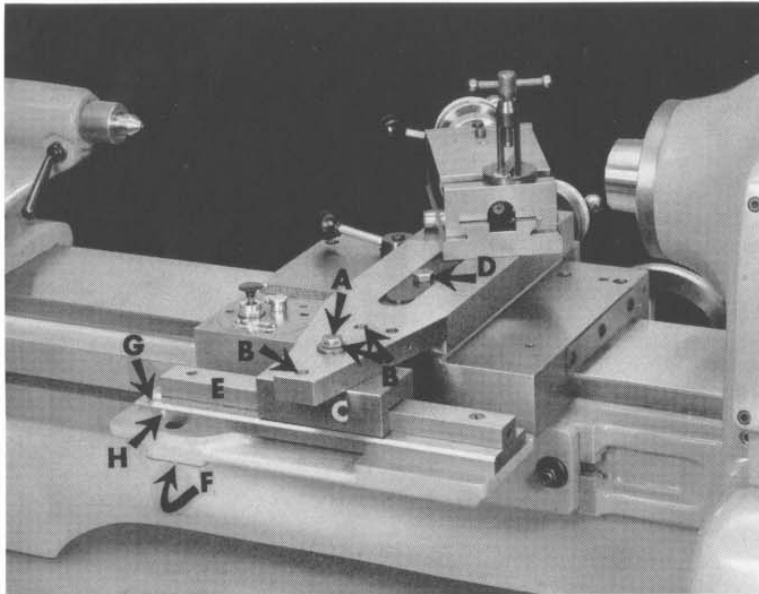

TAPER TURNING ATTACHMENT

The turning or boring of precision tapers is readily accomplished on the Hardinge HLV Lathe by the use of a taper turning attachment. The Hardinge taper turning attachment is based on the sine bar principle — swiveling the guide bar from one end. See Page 3 for a typical taper turning setup.

The taper turning attachment mounts directly on the back of the lathe bed and is adjustable along the bed to suit the work.

In operation, the taper turning attachment is moved into position to suit the work. Clean attachment of all chips and foreign matter. Then place the cross slide in position so that bolt "A", shown in illustration above, can be placed through any one of the three holes "B" in the cross slide to engage the slide "C". With the cutting tool in position and taper attachment secured to cross slide, release 9/16" hexagon cap screw "D" two turns — **DO NOT REMOVE CAP SCREW**. All adjustments of taper attachment are made with 9/16" wrench.

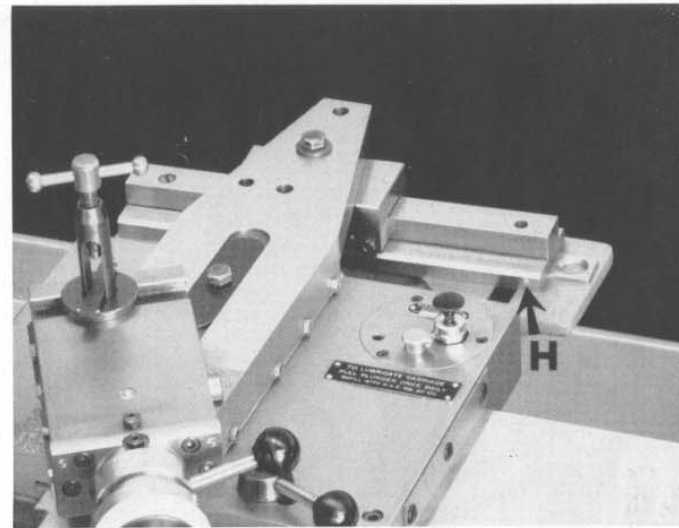

To set guide bar "E" to the desired angle, loosen cap screw "F". Cap screw "F" is located on the under side of the taper attachment body. Swing guide bar "E" to desired angle or taper per foot according to graduation view through zero plate "G".

Lock guide bar in place with cap screw "F". Make a test cut. It may be necessary to move guide bar a very small amount to obtain the exact taper for a blueed fit to the taper gage. Loosen cap screw "F" a very small amount and tap guide bar lightly to move it into position to give exact taper. Then lock cap screw "F" tight. When tapping guide bar "E" strike it on hardened pins "H" protruding from the surface at the sides of the guide bar.

Lubricate guide bar with spindle oil.

IMPORTANT: When turning or boring a taper be sure the cutting tool is exactly on center; otherwise a true taper will not be produced.

A good place to keep the taper attachment when it is not in use is at the tailstock end of the bed since the majority of the work will be done at the headstock end.

CARRIAGE and BED TOOLING

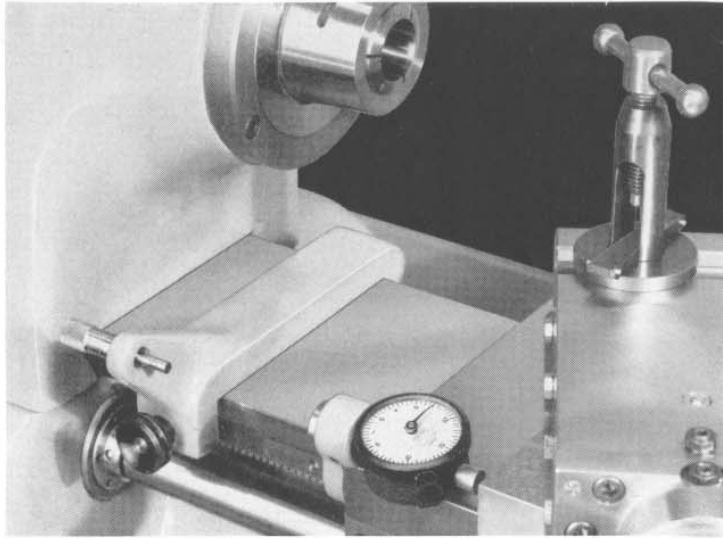

MICROMETER CARRIAGE STOP WITH DIAL INDICATOR

The micrometer carriage stop is a useful accessory when producing parts having exact shoulder lengths.

All Hardinge HLV Lathes are now equipped with a tapped hole in the carriage for fastening the indicator to the carriage. The bracket carrying the micrometer mounts directly to the hardened and ground dovetail bed ways.

The indicator reads in .0005" increments. The micrometer reads in .001". Measurements are made with the micrometer. Carriage is moved until the indicator reads zero.

BED TOOLING

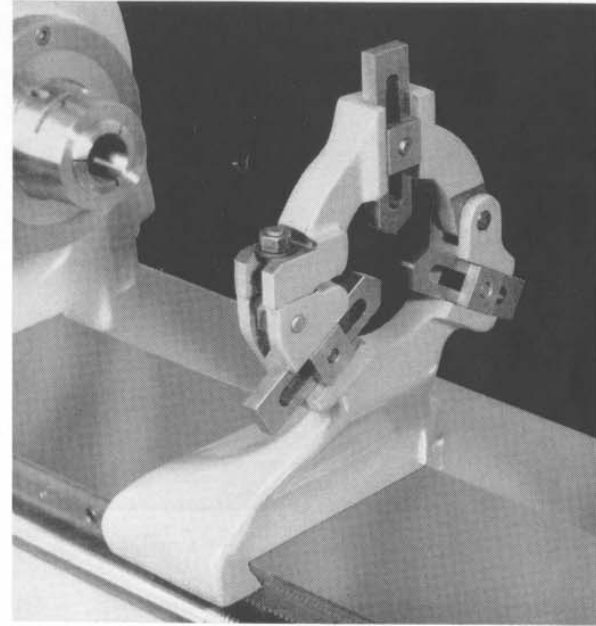

STEADY REST

Long cylindrical work held between centers requires a steady rest to prevent such work from springing away from a cutting tool. A steady rest is also used when there are machining operations to be performed on the end of work which prohibits the use of the tailstock center. The three jaws are adjustable and have an accurate fit in the milled guides of the body. The top section is hinged to provide ease in loading shoulder work without disturbing the setting of the jaws. The steady rest has a maximum capacity of 3".

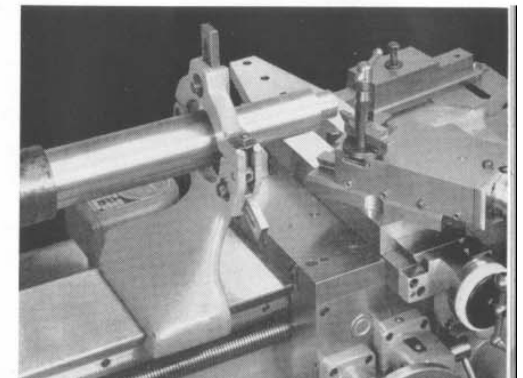

BED TOOLING

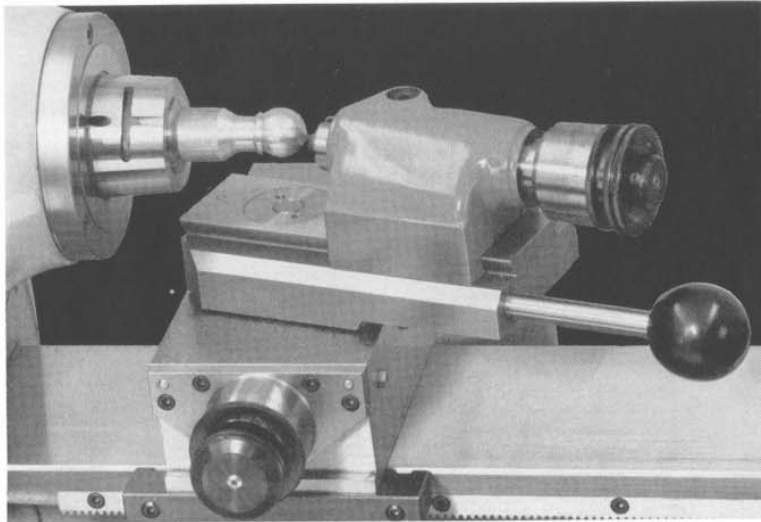

RADIUS TURNING ATTACHMENT

This attachment fastens directly to the dovetail bed, as shown above, and is used for precision turning concave or convex surfaces up to 1-1/2" radius. Useful for turning punches, dies, ball shaped valve seats and special spherical cutting tools.

The swivel slide is mounted on precision preloaded ball bearings for accuracy and rigidity. The swivel slide moves through 360°. Hardened feed screws are mounted on preloaded ball bearings and have adjustable dials graduated in thousandths of an inch.

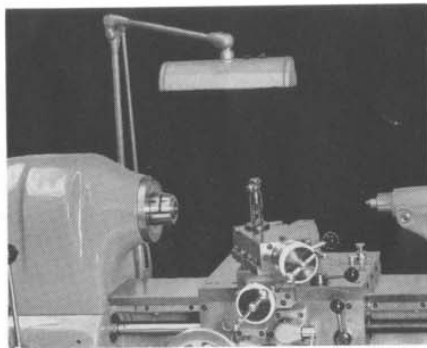

LAMP

This fluorescent lamp is available for use with the Harding HLV Lathe. The lamp fastens to the back of the lathe bed and operates from the regular 110 volt line.

TAILSTOCK TOOLING*

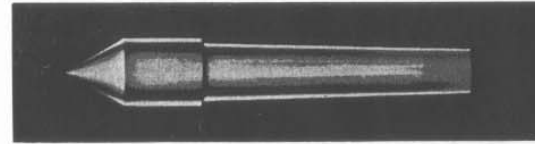

MALE CENTER

This male center has a 11/16" head diameter and is furnished with all Hardinge tailstocks. All centers are hardened and ground.

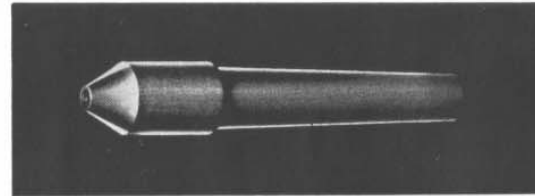

FEMALE CENTER

A female center is used for work that cannot have the usual center hole. The 11/16" head has a 60° conical hole 1/8" in diameter at the large end.

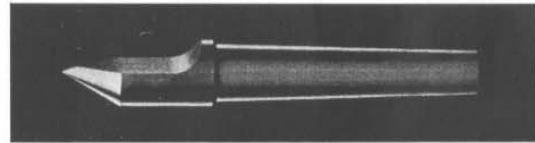

HALF CENTER

A half center is used if tool clearance is desired when turning the full length of a part supported by the tailstock. The head diameter is 11/16".

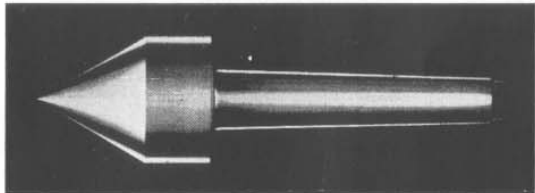

LARGE CENTER

This center has a head diameter of 1". It is indispensable for supporting tubing or recessed work too large for the standard male center.

* When ordering, specify No. 2 Morse Taper Shank.

TAILSTOCK TOOLING*

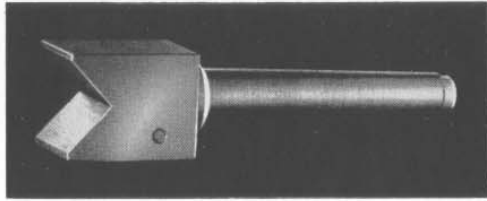

V CENTER

The swivel V center is constructed so the V block rotates on the shank.

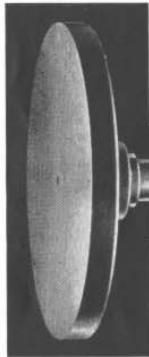

DRILL PLATE

The drill plate, when in place in the tailstock spindle, is used to support work at right angles to the machine spindle center line. The plate is made of close-grained cast iron and has a steel taper shank. The finished face surface is 3-1/2" in diameter.

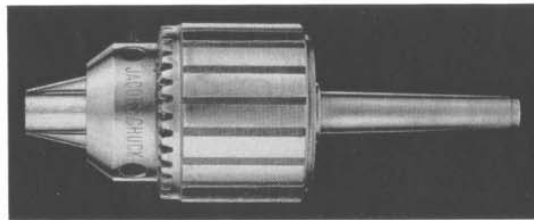

DRILL CHUCK

We recommend the improved type drill chucks with our tailstocks. We carry 0-1/8", 0-3/8" and 0-1/2" sizes in stock mounted ready for use.

* When ordering, specify No. 2 Morse Taper Shank.

TOOLING

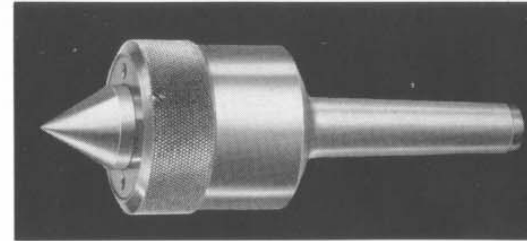

ANTI-FRICTION CENTER FOR TAILSTOCK

This heavy duty anti-friction center has a No. 2 Morse Taper shank for direct application to the tailstock spindle. Work can be done between centers at high speed when the anti-friction center is used.



ADJUSTABLE HEIGHT CHAIR

The seat of the chair has infinite adjustment to suit the operator and can be adjusted without the use of tools. Unlocking and locking, after adjustment of the chair to correct height position, is automatic through the use of a special ball bearing device. The back rest is also adjustable.

TOOLING

TO CUT METRIC THREADS

By the application of a metric attachment to the gear box, in place of the English bracket for the outside change gears, metric threads can be cut. For threading, follow the same procedure as when setting up English threads as described on Page 33.

Gears supplied for the English outside gear can also be used in the gear setup for metric threads.

When metric attachment is supplied with machine, a large gear cover is shipped as standard equipment. When the metric attachment is supplied later, the large cover is supplied to replace the standard cover.

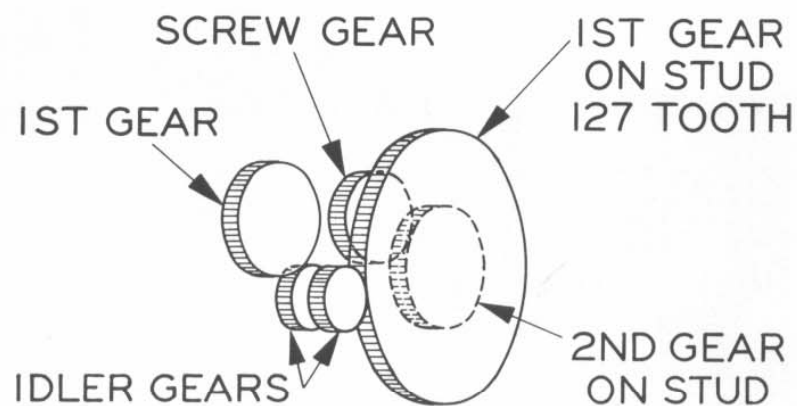

See Gear Chart on Opposite Page

TOOLING

PITCH IN MM	KNOB	FIRST GEAR	SECOND GEAR ON STUD	IDLER GEAR	SCREW GEAR
.1	3	25	40	50	50
.2	2	25	40	50	50
.25	2	25	50	40	50
.30	2	25	60	40	50
.35	3	50	70	30	50
.40	1	25	40	50	50
.45	3	50	54	30	30
.50*	3	50	60	30	30
.55	1	25	55	40	50
.60	1	25	60	40	50
.65	2	50	65	30	50
.70	2	50	70	30	50
.75	3	50	66	30	22
.80	2	50	56	30	35
.85	2	50	68	50	40
.90	2	50	54	30	30
.95	2	50	76	30	40
1.00*	2	50	60	30	30
1.10	1	50	55	30	50
1.20	1	50	60	30	50
1.25	2	50	60	30	24
1.30	1	50	65	30	50
1.40	1	50	70	30	50
1.50	2	50	66	30	22
1.60	1	50	56	30	35
1.70	1	50	68	30	40
1.75	2	50	77	30	22
1.80	1	50	54	30	30
1.90	1	50	76	30	40
2.00*	1	50	60	30	30
2.25	1	60	60	30	32
2.50	1	50	65	30	25
2.75	1	50	66	30	24
3.00	1	50	66	55	22

* Pitches that can be cut with standard gears supplied with machine and metric attachment.

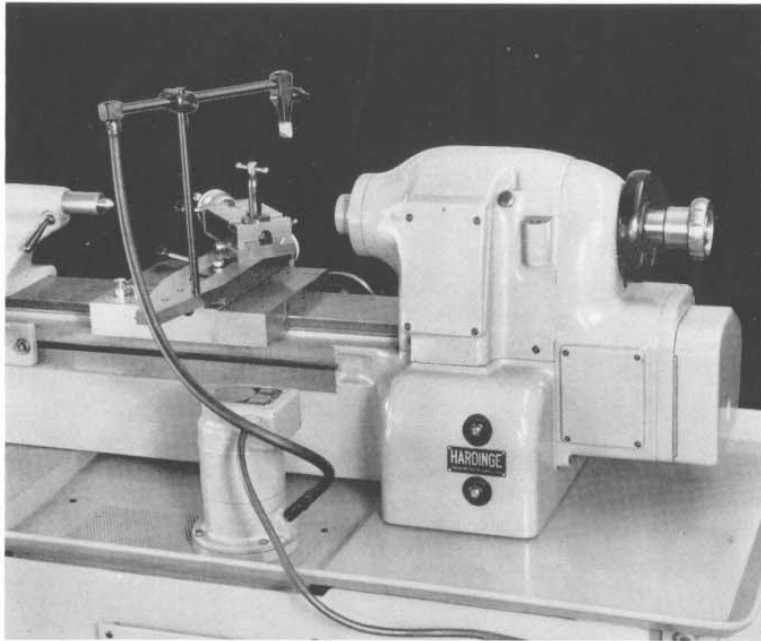

COOLANT FACILITIES

The Hardinge HLV Lathe chip pan has an integral sump built into the sloping bottom chip pan. The coolant facilities can be ordered with the machine or supplied at a later date and installed by the user.

Coolant is always an advantage when machining tough cutting material, particularly when threading. The use of coolant promotes longer tool life and a better quality of work.

The coolant pump motor is controlled by the selector switch at the top of the large electric control panel at the left hand end of the pedestal base.

The pump will handle most common types of oil or soluble coolants. Oil, as a coolant, is recommended.

CAUTION: When using water soluble coolant, be sure the mixture is proper to prevent rusting of the machine and work.

Clean the sump regularly, depending upon the type of material being machined. When doing dry machining of cast iron or other powdery material, cover the sump screen to prevent fine material from mixing with the coolant. To clean sump remove the four screws, one in each corner of the screen cover for sump. Lift pump and screen assembly from sump. Clean sump. Rinse out and drain sump by removing pipe plug from bottom of sump. This plug is easily accessible from the back of the machine.

A metal splash guard for the spindle, as shown in the illustration, is standard equipment with the coolant facilities.